

# Generator Start Control Module

## Part# GSCM-mini-P

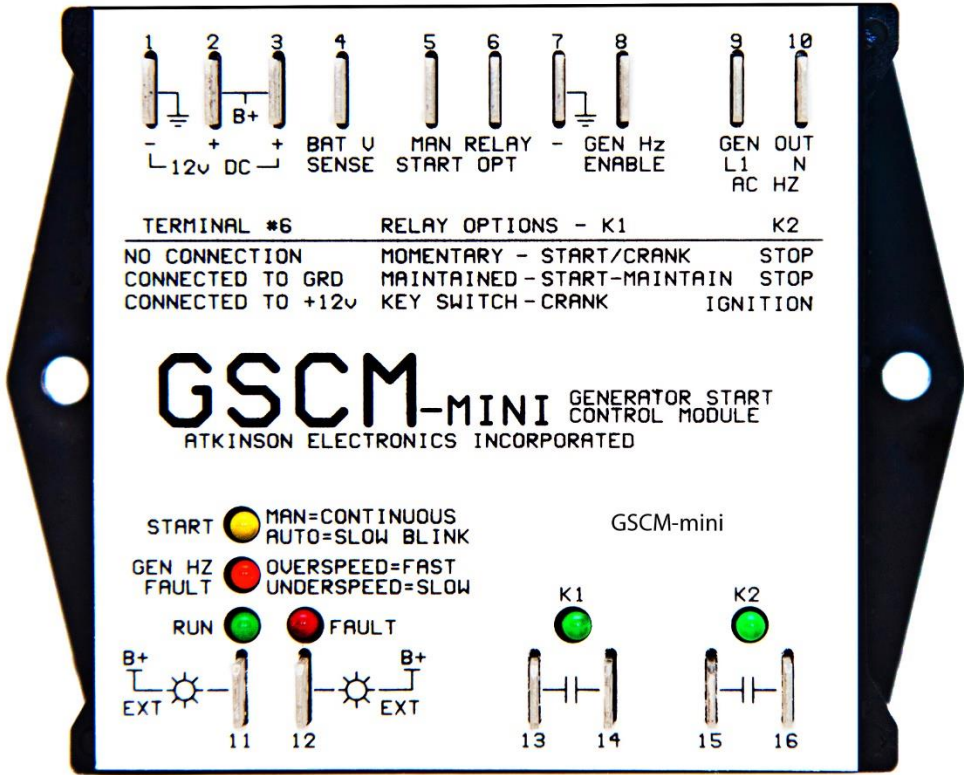

**ATKINSON ELECTRONICS, INC.**

14 West Vine Street · Murray, Utah 84107



# Table of Contents

Modes of Relay Operations.....	3
LED Indication Description .....	3
Operational Thresholds .....	3
Typical Wiring Diagram .....	4
Option 1 Diagram .....	5
Option 2 Diagram .....	5
Option 3 Diagram .....	5
Option 1 Starting Sequence .....	6
Option 2 Starting Sequence .....	7
Option 3 Starting Sequence .....	8
Manual Off Auto Switch Options .....	9
Fault Shutdown Conditions.....	9
Automatic Starting for Battery Charging.....	10
Generator Emergency Shutdown.....	10
LED Description and Meanings.....	11
Specifications .....	11
Remote RV Generator Start Drawing .....	12
Outback Inverter/Inverter Style Drawing.....	13
Outback Inverter/Honda EUxx00is Drawing....	14
Samlex America EVO Inverter Drawing.....	15
Limited Warranty.....	16

---

*Solving your generators two to three wire start-stop problem.*

---



**Not Included But.....**  
Outback 48 Volt inverter systems require isolation relay A0365

## Features & Applications

- Inexpensive 2 wire to 3 wire start controller for electric push to start/stop Duel fuel generators
- Optimized for use with Outback Invertors
- Supports four manufactures generator control: Champion, Cummins/Onan, Duramax and Westinghouse
- Fixed start/stop pulse times, accounts for multiple start attempts by generator’s ECU
- Maximum auto-start run time limit (6 hours)
- Remote run and fault indication included
- ABS epoxy sealed for harsh environment operation
- 

## Description

The GSCM-mini-P (Pulse) is a micro-processor based generator start-stop module, designed to auto start-stop generators that need a 3 to 4 wire connection from a 2 wire 12 volt manual start command. The GSCM-mini-P automatically goes into run mode when it either receives a remote start indication lamp signal (*connected to terminal 8*) or an AC Hz signal from the generator (*AC connected to terminals 9 & 10*). Various LEDs are blinked or turned on to indicated the run or fault status of the GSCM-mini-P. Manually resetting the GSCM-mini-P by removing the power and removes any lockout that allows the generator to restart if called to do so.

The GSCM-mini-P is powered by 12VDC from the generator battery and can monitor the battery voltage and start the generator to charge its own battery. The GSCM-mini-P is a limited function controller that is part of the GSCM family.

***All auto start battery voltage thresholds are fixed, if adjustability is required use the GSCM full function Generator Start Control Module.***



## Three Modes of Relay Operation

---

There are 3 program options based on the generator make for the GSCM-mini-P's two relay contacts to be configured: **Champion, Cummins/Onan & Westinghouse, and Duramax**

---

*This is accomplished with an optional jumper on terminal 6.*

---

**Option #1 Champion's inverter generator:** *Terminal 6 has no connection.* The GSCM-mini-P program is configured for a 1 second pulse (K1) to wake up the generator's ECU, and a second 1 second pulse (K1) to begin the generators start sequence. On shutdown, the K2 relay produces a 1 second pulse for the ECU to stop the generator. See Section 1 for operation description.

**Option #2 Cummins/Onan & Westinghouse generators:** *Terminal 6 connected to B+ (12VDC).* The GSCM-mini-P program configures K2 for maintained operation and K1 for 1 second start/stop pulse operation. The K2 contact wires in parallel with the power switch and K1 wires in parallel with the push button switch. A SPDT relay is used to open the connection between ground and the Ignition coil. See Section 2 for operation description.

**Option #3 Duramax generator:** *Terminal 6 is connected to ground.* The GSCM-mini-P program is similar to option #2, instead of 3 start attempts per 1 second start pulse, It is configured for Duramax's single 1 to 5 second start pulse, if the generator fails to start during the 5 second start pulse, the mini-P generates another start pulse, is will attempt up to 6 times to start the generator before going into a fault. See section 3 for operation description.

---

*If adjustability is required then refer to the GSCM full function control module.*

---

## LED Indication Description

---

The GSCM-mini-P has six indication LEDs.

**The Start LED** blinks every 5 seconds to indicate it is ready for a start signal. The LED will blink every 2.5 seconds to indicate its running in auto start mode. On continuously indicates running in manual start mode.

**The Generator Hz LED** blinks to indicate over/under Hz fault and start failure due to maximum crank attempted. A slow blink indicates an under Hz condition while a fast blink indicates an over Hz condition. On continuously indicates AC present in a non-run condition. A double blink indicates a start failure condition. Four blinks indicates generator shut down due to its own fault condition or lack of fuel.

**The Run LED,** On continuously indicates a valid run signal from the generator.

**The Fault LED,** On indicates a fault condition has occurred and GSCM-mini is in lockout and must be reset.

**The K1 and K2 LEDs** indicate the relay status.

## Operational Thresholds

---

GSCM-mini-P' fixed operational thresholds:

Start Pulse:	1 to 5 seconds		
AC Crank Disconnect:	45Hz		
DC Crank Disconnect	Voltage greater than 9VDC		
Under Speed Shutdown:	55Hz		
Over Speed Shutdown:	65Hz		
Max Auto Start Run time:	6 Hours		
Manual Start Run Time:	Indefinitely		
Auto Start/Stop Thresholds:	Start	Stop	
12V system	11.5V	13.8V	Standard
24V system	23.0V	27.6V	Auto selects
48V system	46.0V	55.2V	Auto selects
Relay Configuration:	Open input = Momentary Crank		
(Terminal 6)	Grounded input = Maintained Crank		
	B+ (12VDC) input = Ignition & Crank		

Fault Detection:

- Start failure (Depends on option)
- Over Hz condition (10 seconds)
- Under Hz condition (10 seconds)
- Max run time auto restart within 30m
- Generator stops due to its own fault condition



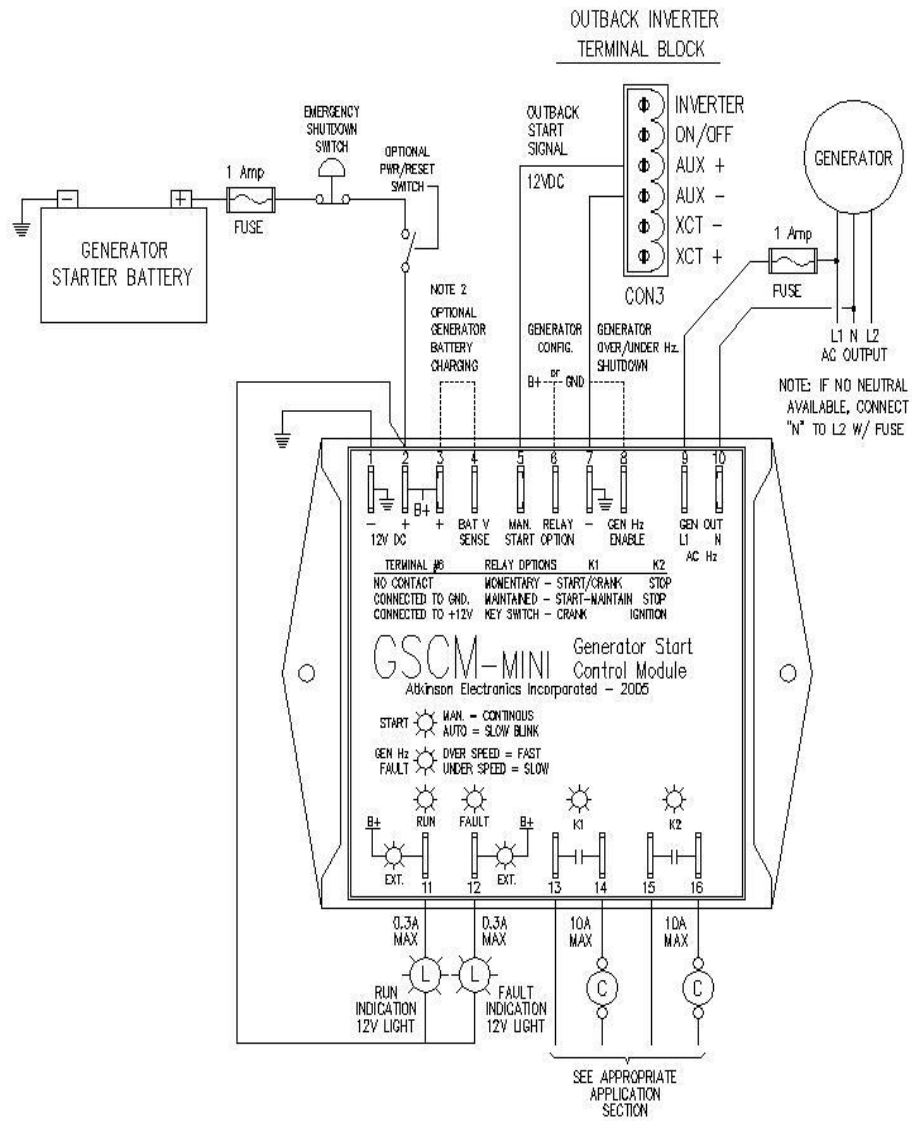

The GSCM-mini-P accepts Outback's 2 wire switched 12VDC start /run signal or a dry contact, like Samlex, Trace and others, it produces a 3-4 wire start/stop signal for most gas and propane generators. Using the generators remote port and remote pilot lamp (PL) signal, if available, can make for a quick and easy installation, otherwise it is wired in parallel with the power and push to start/stop switch. The Pilot Lamp signal or 120/240VAC provides feedback telling the GSCM when the generator has started and when the generator has completely shut down. A red connector with a protection diode is provided to connect between terminal 8 on the GSCM-mini and pilot lamp wire for applications where the pilot lamp signal is positive or high. If the pilot lamp signal is negative or goes low the pilot lamp signal inverter must be used, see Inverter Style Generator. **The GSCM-mini-P's configuration terminal # 6 has no connection, the starting sequence is as follows:**

1. The start LED blinks once every 5 seconds to indicate that the GSCM-mini is in a "ready" mode. When a manual signal is received, the start LED lights continuously. After a 2 second delay, the K1 relay provides a 1 second pulse to wake up the generator's ECU, then after a second 2 second delay it provides another 1 second pulse to initiate the ECU's starting sequence. The Champion's ECU will provide up to six starting attempts.
2. If the generator fails to start during six starting attempts and rest periods, approximately 90 seconds, the GSCM-mini-P provides a 1 second pulse on the K2 relay to ensure the generator is not running and then enters the failed to start fault. The Generator Hz LED does a double blink, the fault LED turns on and the GSCM-mini enters the maximum crank lockout fault condition. This lockout condition remains until the GSCM-mini is reset by removing power from terminal 2, waiting 5 seconds and then reconnecting power (see GSCM-mini wiring diagram, page ??). This clears the lockout condition, and the GSCM-mini re-enters "ready" mode with the start LED blinking every 5 seconds.
3. When the generator starts, the GSCM-mini-P's green Run LED turns on, indicating that it received a valid run signal. A valid run condition is determined by one of two conditions: A 12V run status pilot light signal provided by the generator connected to terminal 8, or by generators AC output frequency exceeding the crank disconnect setting of 45Hz (terminals 9 & 10).
4. If the generator starts but shuts down after a few seconds due to a fuel problem, etc., the GSCM-mini-P exits the run mode, energizing the K2 relay for 1 second, then enters a 60 second delay period blinking the yellow start LED rapidly, then returns to "ready" mode. The GSCM-mini-P will then try to start the generator again in manual mode or after a 5 minute delay period in auto-start mode.
5. If the generator starts but shuts down after the 60 seconds stabilization period, due to a fuel problem, low oil pressure, broken AC Hz or 12V run status wire, the GSCM-mini-P exits the run mode, energizing the K2 relay for 1 second, then turns on the Red Fault LED and blinks the generator Hz orange LED 5 times with a 2 second delay between blinks. The GSCM-mini enters a fault shutdown lockout condition and must be powered down to reset the fault lockout.
6. When a run condition is detected, the GSCM-mini turns on the green run LED and transistor output (remote run lamp terminal 11).
7. If no faults occur, the generator will continue to run until one of the following occurs: The manual start signal is no longer received and the auto battery charge voltage or maximum auto run time has been reached, while running in auto charge mode over Hz condition, under Hz condition occurs if the generator over/under Hz shutdown is enabled, or the generator runs out of gas



The GSCM-mini-P's configuration terminal # 6 is connected to +12VDC (terminal # 3), this configures the GSCM-mini-P for a 1 second start/stop pulse on the K1 relay contact and a maintained power/run on the K2 contact. When the GSCM-mini-P is powered by connecting B+ (12.0 VDC) to terminal 2, the Start LED turns on for 5 seconds while the GSCM-mini initializes with option #2 configuration then begins blinking the start LED once every 5 seconds. The GSCM-mini's starting sequence is as follows.

1. The start LED blinks once every 5 seconds to indicate that the GSCM-mini is in a "ready" mode. When a manual start signal is received, the start LED lights continuously. After a 2 second delay, K2 relay energizes closing its normally open contact to power the generator's ECU, then after another 2 second delay, it provides a 1 second start pulse by energizing the K1 relay contact for 1 second. The generator's ECU then makes three attempts to start the generator.
2. If the generator fails to start during the three starting attempts and rest periods, approximately 50 seconds, the generator will go into a failed to start fault requiring the generator's ECU to be reset by powering down the generator. The GSCM-mini-P starts a 1 minute timer when it provides the start pulse and looks for a valid run feedback signal.
3. The run feedback signal can be either: a 12vdc status pilot lamp signal provide by the generator that is connected to the GSCM-mini-P's terminal #8, or by the generator producing its 120VAC output which would be connected to the GSCM-mini-P's GenHz input (terminal #9 and 10).
4. When the generator starts and the GSCM-mini-P receives the feedback signal it drops in to the run mode turning on the green run LED.
5. If the generator fails to start after 3 three starting attempts, the GSCM-mini-P's 1 minute start timer expires and the GSCM-mini runs thru its re-start routine, de-energizing the K2 relay powering down the generator, which clears it failed to start fault, then waits 15 seconds and repeats the starting routine.
6. If the generator fails to start after the second round of three attempts the GSCM-mini-P turns on its red fault LED and the GSCM-mini enters the Maximum crank lockout condition and the Generator Hz LED does a double blink. This lockout condition remains until the GSCM-mini is reset by removing power from terminal 2, waiting 5 seconds and reconnecting power. This clears the lockout condition, and returns to ready mode.
7. If the generator starts but shuts down after a few seconds due to a fuel problem, etc. The GSCM-mini goes thru its shutdown routine then re-enters ready mode after a 60 second delay. During this delay the start LED will blink rapidly. The GSCM-mini will then try to start the generator again in manual mode or after a 5 minute delay period in auto-start mode.
8. When a run condition is detected, the GSCM-mini turns on the run LED and open collector transistor output (remote run lamp) and after a 60 second generator stabilization period it monitors the run feedback signal.
9. If the generator starts but shuts down after the 60 seconds stabilization period, due to a fuel problem, low oil pressure, broken AC Hz or 12V run pilot light status wire, the GSCM-mini turns off the run LED and turns off K2 relay, and turns on the fault LED blinks the orange GenHz LED five times every two seconds. The GSCM-mini enters a fault shutdown lockout condition and must be powered down to reset the fault lockout.
10. If no faults occur, the generator continues running until one of the following occurs: The manual start signal is no longer received, the auto battery charge voltage or max run time has been reached while running in auto charge mode, an over or under Hz condition occurs if generator Hz shutdown is enabled or the generator runs out of gas.
11. Shutdown routine, K1 provide a 1 second stop pulse, then 15 second later K2 relay de-energizes, powering down the generator.
12. The generator remains off until another start signal is received.



The GSCM-mini-P's configuration terminal # 6 is connected to ground (terminal # 7), this configures the GSCM-mini-P for a 1 second start/stop pulse on the K1 relay contact and a maintained power/run on the K2 contact. When the GSCM-mini-P is powered by connecting B+ (12.0 VDC) to terminal 2, the Start LED turns on for 5 seconds while the GSCM-mini initializes with option #3 configuration (generators that do not have multiple starting attempts) then begins blinking the start LED once every 5 seconds. The GSCM-mini's starting sequence is as follows:

1. The start LED blinks once every 5 seconds to indicate that the GSCM-mini is in a "ready" mode. When a manual start signal is received, the start LED lights continuously. After a 2 second delay, K2 relay energizes closing its normally open contact to power the generator's ECU and will remain energized for the duration of the start and run cycle. Then after another 2 second delay, the mini provides a 1 second start pulse by energizing the K1 relay contact for 1 second. The generator's ECU then **makes one attempt** to start the generator.
2. If the generator fails to start during the starting attempt and the run feedback period, approximately 15 seconds, the GSCM-mini will again provide a one second start pulse, followed by the run feedback period watching to see if the generator has started. It will provide a total of six start attempts.
3. The run feedback signal can be either: a 12vdc status pilot lamp signal or a 12vdc charging port provided by the generator that is connected to the GSCM-mini-P's terminal #8, or by the generator producing its 120VAC output which would be connected to the GSCM-mini-P's GenHz input (terminal #9 and 10).
4. When the generator starts and the GSCM-mini-P receives the feedback signal it drops in to the run mode turning on the green run LED.
5. If the generator fails to start after 6 starting attempts, the GSCM-mini-P turns on its red fault LED and the GSCM-mini enters the Maximum crank lockout condition and the Generator Hz LED does a double blink. This lockout condition remains until the GSCM-mini is reset by removing power from terminal 2, waiting 5 seconds and reconnecting power. This clears the lockout condition, and returns to ready mode.
6. If the generator starts but shuts down after a few seconds due to a fuel problem, etc. The GSCM-mini goes thru its shutdown routine then re-enters ready mode after a 60 second delay. During this delay the start LED will blink rapidly. The GSCM-mini will then try to start the generator again in manual mode or after a 5 minute delay period in auto-start mode.
7. When a run condition is detected, the GSCM-mini turns on the run LED and open collector transistor output (remote run lamp) and after a 60 second generator stabilization period it monitors the run feedback signal.
8. If the generator starts but shuts down after the 60 seconds stabilization period, due to a fuel problem, low oil pressure, broken AC Hz or 12V run pilot light status wire, the GSCM-mini turns off the run LED and turns off K2 relay, and turns on the fault LED blinks the orange GenHz LED five times every two seconds. The GSCM-mini enters a fault shutdown lockout condition and must be powered down to reset the fault lockout.
9. If no faults occur, the generator continues running until one of the following occurs: The manual start signal is no longer received, the auto battery charge voltage or max run time has been reached while running in auto charge mode, an over or under Hz condition occurs if generator Hz shutdown is enabled or the generator runs out of gas.
10. Shutdown routine, K1 provide a 1 second stop pulse, then 15 second later K2 relay de-energizes, powering down the generator.
11. The generator remains off until another start signal is received.



The manual start signal is created by connecting terminal 5 (manual start) to terminal 3 (B+12VDC) through a power/reset switch. It may also be generated by an Outback Inverter using the AUX+/- connections on the remote terminal block. The Outback provides a switched +12VDC signal for the GSCM-mini 60Hzs manual start input. An optional manual-off-auto switch can be installed to provide user flexibility for manual starts, resets, turning the unit off, or auto starting from inverter. See GSCM-mini 60Hzs wiring diagram, upper right hand corner.

## GSCM-mini 60Hz

## Fault Shutdown Conditions

The GSCM-mini 60Hz detects five fault shutdown conditions, they are as follows:

1. Failure to start with 3 cranking attempts (see Section-1:2, 2:2,5, & 3:2,5). The generator Hz shutdown LED does a double blink and fault LED on continuously.
2. High frequency (over Hz) condition. If the generator AC output is connected to terminals 9 and 10 and the generator Hz enable terminal #8 is grounded, the GSCM-mini monitors the generators output frequency and if it exceeds the 65 Hz fixed threshold for 10 seconds, the generator shuts down and the generator Hz shutdown LED blinks rapidly. The generator Hz LED blinks during this 10 second period.
3. Low frequency (under Hz.) condition. If the generator AC output is connected to terminals 9 and 10 and the generator Hz enable terminal #8 is grounded, the GSCM-mini monitors the generators output frequency and if it drops below the 55 Hz fixed threshold for 10 seconds, the generator shuts down and the generator Hz shutdown LED blinks slowly. The generator Hz LED blinks during this 10 second period.
4. Auto Start within 30 minutes of max run time shutdown (see Section-6:4). The generator Hz shutdown LED does a triple blink and fault LED on continuously.
5. Generator shuts on its own fault. While the GSCM-mini is in run mode, and the generator is running, if the generator shuts down on a fault condition (low oil pressure, hi temperature, or out of fuel) or the AC Hz signal fuse or wire opens or the 12V run status wire opens, the GSCM-mini goes thru its shutdown routine and enters a fault condition, turning on the red fault LED and blinking the generator Hz LED four times every two seconds.

The over/under Hz detection not enabled until the generator has been running for 60 seconds and will shut down the generator after 10 continuous seconds of Hz fault condition, locking it out until a power down reset and power back up. The fault open collector transistor output (terminal 12) will energize a user supplied remote lamp or DC relay (not exceeding 300 milliamp coil current) whenever a fault shutdown occurs and will de-energize the relay when the fault is reset.





The GSCM-mini-P can monitor either the generator battery voltage or a battery bank voltage and automatically start/stop the generator based on battery voltage. This is accomplished by connecting the battery voltage to the battery sense input (terminal 4). The GSCM-mini 60Hz monitors a battery voltage range of 0 to 60VDC and automatically determines the start and stop set point based on battery voltage (12, 24, or 48VDC). Below 16VDC - uses 12V thresholds, between 16 to 32V -uses 24V thresholds, above 32V - uses 48V thresholds. This mode is disabled if the voltage on terminal 4 is less than 6V, (no connection).

1. The GSCM-mini-P monitors the battery sense input and when the battery voltage drops below the start threshold the Start LED begins blinking every second. When the battery voltage has remained below the start threshold for 5 continuous minutes the auto start sequence begins. If the battery voltage rises above the start threshold during the 5 minute period the 5 minute timing cycle starts over. (Temporary battery voltage fluctuations such as instantaneous inverter loads will not start the GSCM). The start LED blinks every 3 seconds while the GSCM-mini is running the generator in auto-start mode.
2. The GSCM-mini-P starts the generator as described in each of the three generator type sections.
3. The GSCM-mini-P shuts down the generator (as described in [Sections 1, 2, or 3](#)) whenever the battery voltage exceeds the stop threshold for 10 minutes. The Start LED blinks (every second) during this 10 minute period. The GSCM-mini will exit the 10 minute period and shutdown the generator if the battery voltage exceeds the stop threshold by +1.0V for a 12V system, 2V for 24V system and 4V for a 48V system. The generator remains off until the battery voltage drops below the start threshold voltage.
4. The GSCM-mini-P will shut down the generator when it has run in auto-start battery charging mode for 6 hours and has not charge the battery above the shutdown threshold. The GSCM-mini-P then returns to ready mode looking for a start command. If the battery voltage drops below the Auto start threshold within 30 minutes of a max run time shut down the GSCM-mini-P will enter a max run time fault condition and lock out the start sequence and requires a power down reset. The generator Hz LED will blink 3 quick blinks every 5 seconds and the fault LED is on continuously.
5. If the user wishes to manual-start the generator from a separate pressure switch, level switch, thermostat or inverter start contact, etc., the battery voltage is fed through the switch (pressure switch etc.) contact to Manual start terminal 5. Closing the contact will cause the GSCM-mini to start the generator. Some inverters provide a switch 12VDC signal to start the generator. This switched voltage can be connected directly to the manual start terminal 5 and ground terminal 7.

The GSCM-mini-P Generator Start Stop module is **NOT AN EMERGENCY SHUTDOWN DEVICE!** If the manual start signal is removed the generator will go through a normal shutdown which may take up to 15 seconds to completely shut down the generator.

A RECOMMENDED EMERGENCY SHUTDOWN SOLUTION is to install a separate "Kill" switch and label it as such. The recommended wiring is shown on [page-2](#) of these instructions and also in [Application 1](#). Disconnecting the power to the GSCM-mini module will force the relays to open. This will shut down generators that require a maintained run signal from K1 relay. However this also prevents the K2 relay from closing to shut down those generators requiring a momentary stop signal. Using a double pole "Kill" switch and wiring the second pole in parallel with the K2 relay terminals will force the generator to stop in an emergency situation such as a fuel spill. ([See note 1 on wiring diagram, page 2, for Ignition/crank emergency shutdown option](#)).



## LED Description and Meanings

---

<b>Start:</b>	One blink every 5 seconds = ready mode, looking for a start signal One blink every 2.5 seconds = auto start mode operation One blink every other second= auto start/stop period Continuous = manual start signal received Fast blink = 60 second delay after start signal removed before generator started
<b>Generator Hz Shutdown</b>	Fast blink = over speed condition Slow blink = under speed condition Double blink = maximum crank attempts reached, failed to start Triple blink = auto start attempted with-in 30 minutes of a max run time (6 hour ) shutdown Four blinks every 2 seconds = AC Hz or 12V run status signal lost during run mode Continuous = start function disabled, AC Hz detected while in ready mode
<b>Run</b>	Continuous = GSCM-mini has a valid run signal from generator
<b>Fault</b>	Continuous = GSCM-mini is in a fault condition and requires a reset
<b>K1 &amp; K2</b>	Continuous = status of K1 and K2 relays on

## Specifications

---

<b>Size:</b>	5.13" L x 2.853" W x 1.35" H	<b>Gen. Hz Enable:</b> (Terminal 8)	Open input = Generator Hz shutdown not active
<b>Weight:</b>	20oz.		Grounded input = Generator Hz shutdown active
<b>Mounting:</b>	2 screws through tabs		12VDC input = Generator run Status input
<b>Power:</b>	12VDC Battery 9.5 to 15VDC Quiescent current < 10mA Relay current < 25mA each		Over/under Hz shutdown not active
<b>Manual Input:</b>	B+ (12VDC) input = on condition Open input = off condition	<b>Frequency Input:</b> (Terminals 9 & 10)	24VAC, 120VAC & 240VAC 0-100 Hz
<b>Battery Input:</b>	0-60VDC	<b>Output Ratings:</b>	Two 10 AMP 28VDC relay contacts, K1 has 38VDC MOV across contact. Two open collector NPN transistors, maxium 300mA each
<b>Auto Start/ Stop Threshold:</b>	12V System 11.5V, 13.8V 24V System 23.0V, 27.6V 48V System 46.0V, 55.2V	<b>Fault Detection:</b>	Start failure, (3 attempts) Over Hz condition (10 seconds) Under Hz condition (10 seconds) Max run time (6 hours) Loss of AC Hz or 12V run status signal
<b>Relay Configuration:</b> (Terminal 6)	Open input = momentary crank Grounded input = maintained crank B+ (12VDC) input = ignition & crank		
<b>Ambient Temp:</b>	-40 to 85°C		



Champion 100573 4KW Generator w/Wireless Remote

- Items needed:
- 1pc A0227 GSCM-mini-Pulse
- 2pc A0409 1 Amp inline fuse

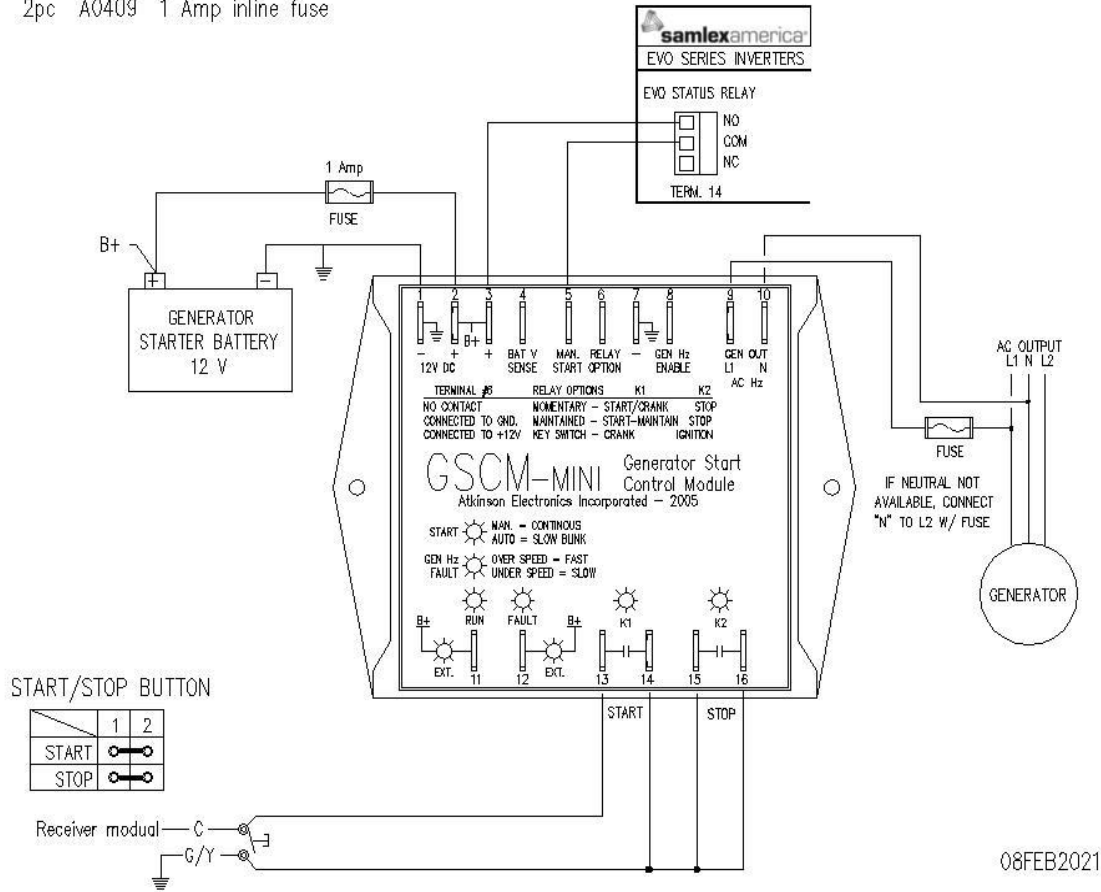

The GSCM-mini-P's K1 &K2 relay contact wire in parallel with each other and the generators Start/Stop push button. The GSCM-mini-P's K1 relay provides the turn on one second pulse and then 2 seconds later provides a second pulse to start the generator. The K2 relay contact provides the stop pulse to shutdown the generator. The GSCM-mini\_p monitors the AC output to know when the generator has started. The Champion ECU provides up to six starting attempts before going into a fault condition.

The GSCM-mini-P's terminal #6 is **not connected**. Terminal #3 (+12vdc) is connected to Samlex's normally open relay contact, and the common contact wires back to terminal #5 on the GSCM-mini-P. The generators AC output is wired to terminals # 9 & 10 providing the run feedback signal. An optional Battery tender/charger is not needed for this option.

The GSCM-mini-P accepts Samlex's two wire relay contact (maintained run signal) and provides a one second start /stop pulse as outlined on page 5 GSCM-mini-P option#1.



Cummins Onan P4500I Inverter Gas Generator

Items needed:

- 1pc A0227 GSCM-mini-P
- 2pc A0409 1 Amp inline fuse
- 1pc A0365 SPST 12VDC Relay
- 1pc A0366 SPDT 12VDC Relay

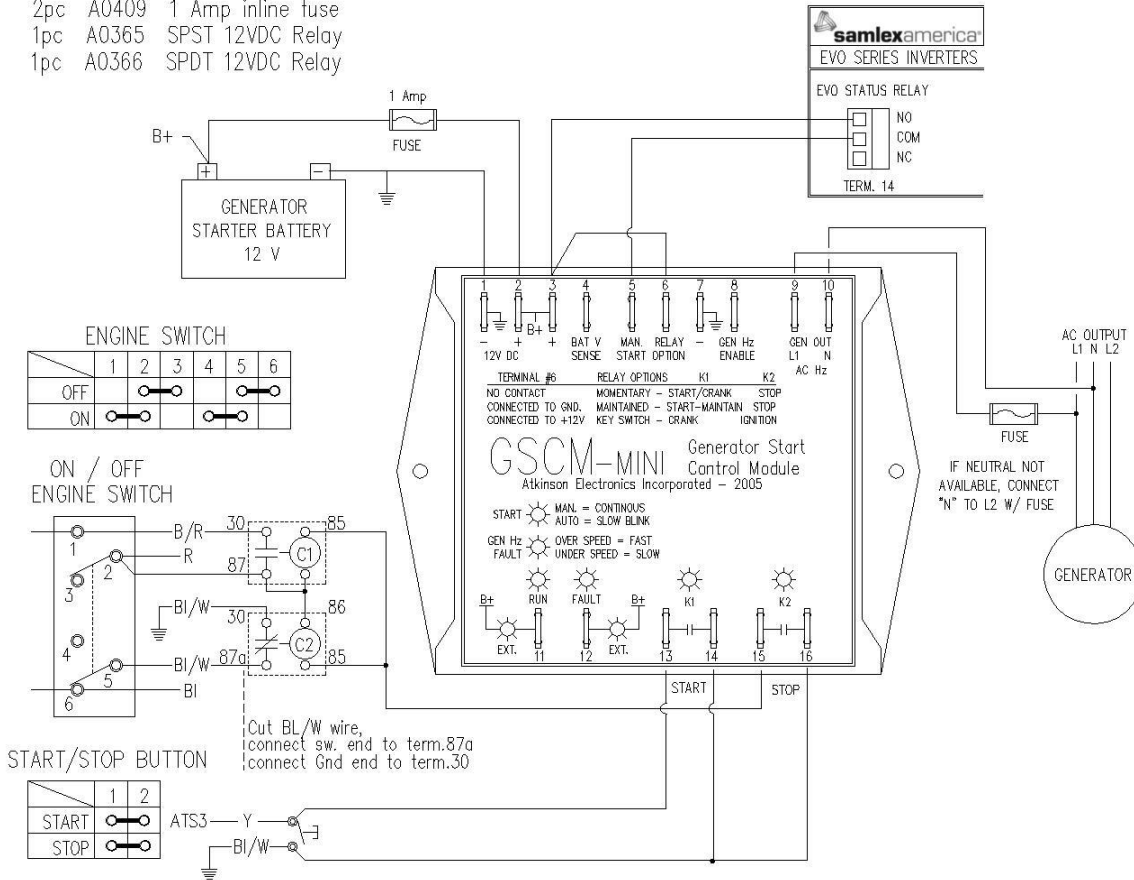

05Jan17

The GSCM-mini-P's K1 relay contact wire in parallel with the generators Start/Stop push button. It's K2 relay contact wires to two control relays, C1's normally open (87) and common (30) tabs, wires in parallel with the engine switch terminals 1 & 2 which are the power contacts. C2's normally closed (87a) and common (30) tabs, wires in series with the ground wire that connects to terminal 5 of the engine switch, when not energized it grounds the ignition coil. Engine switch to be left in the OFF position.

The GSCM-mini-P's terminal #6 is connected to terminal #3 (+12vdc) and to Samlex's normally open relay contact, and the common contact wires back to terminal #5 on the GSCM-mini-P. The generators AC output is wired to terminals # 9 & 10 providing the run feedback signal. An optional Battery tender/charger is not needed for this option.

The GSCM-mini-P accepts Samlex's two wire relay contact (maintained run signal) and provides a one second start /stop pulse as outlined on page 6 GSCM-mini-P option#2.



Cummins Onan P9500DF Dual Fuel Generator

- Items needed:  
 1pc A0227 GSCM-mini-P  
 2pc A0409 1 Amp inline fuse  
 1pc A0366 SPDT 12VDC Relay

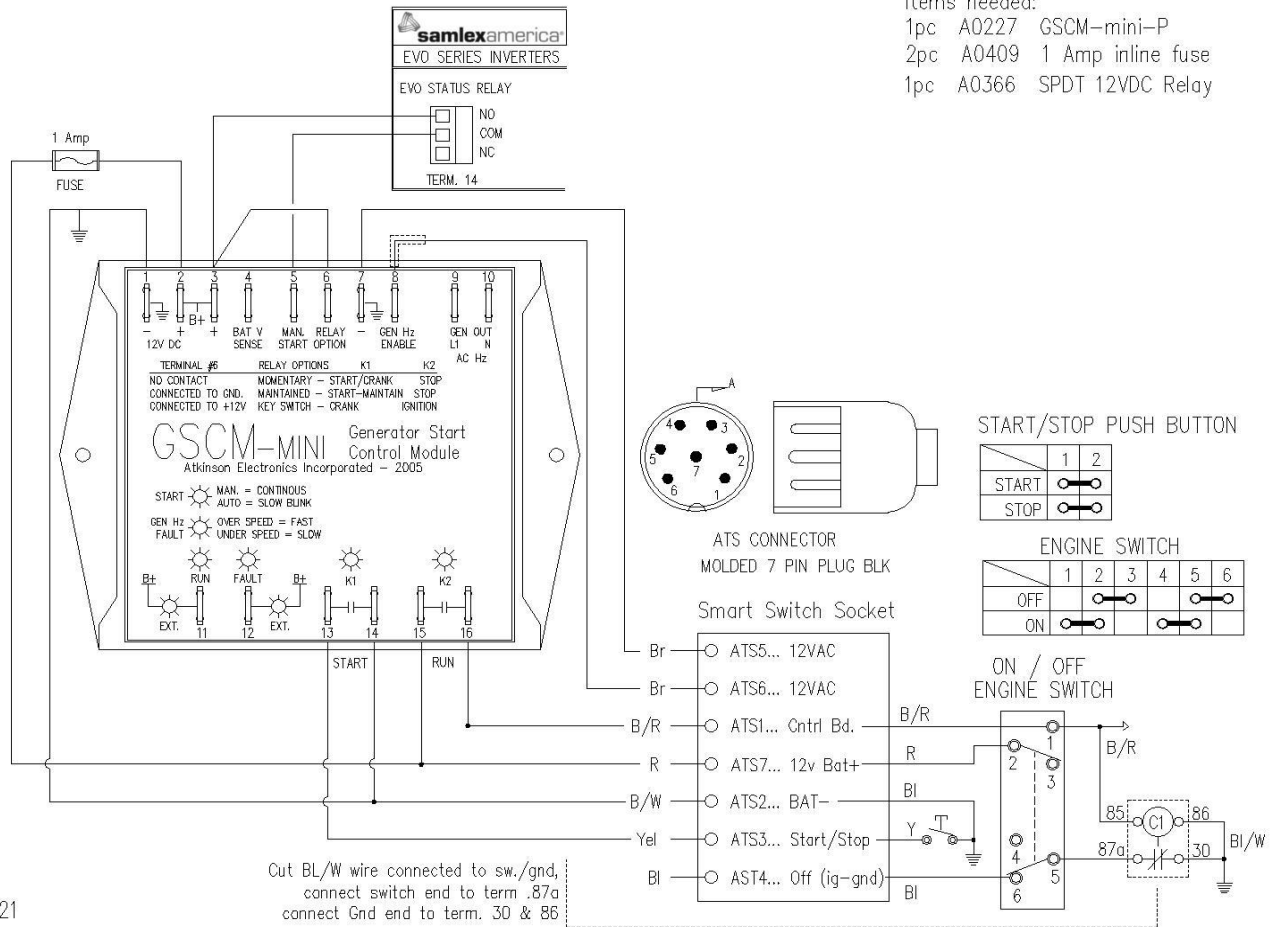

The GSCM-mini-P uses the generator’s Remote/ATS connector for all connections to the generator. The GSCM-mini-P’s power, relay and run feedback connections us the ATS connector as shown above. A control C1 relay is wired in series with the ground wire to break the ground connection running to the engine switch terminal #5. The C1 relay connects as follows terminals 86 and 30 connect to ground, terminal 85 connects to engine switch terminal #1 and terminal 87a connects to engine switch #5. Engine switch to be left in the OFF position.

The GSCM-mini-P’s terminal #6 is connected to terminal #3 (+12vdc) and to Samlex’s normally open relay contact, and the common contact wires back to terminal #5 on the GSCM-mini-P. The generators DC output is wired to terminals # 7 & 8 providing the run feedback signal. An optional Battery tender/charger is not needed for this option.

The GSCM-mini-P accepts Samlex’s two wire relay contact (maintained run signal) and provides a one second start /stop pulse as outlined on page 6 GSCM-mini-P opion#2.

If a battery tender/charger is used, the engine switch should be left in the ON position and the C1 control relay is not used.



Westinghouse WGen4500i Inverter Gas Generator

Items needed:

- 1pc A0227 GSCM-mini-P
- 2pc A0409 1 Amp inline fuse
- 1pc A0366 SPDT 12VDC Relay

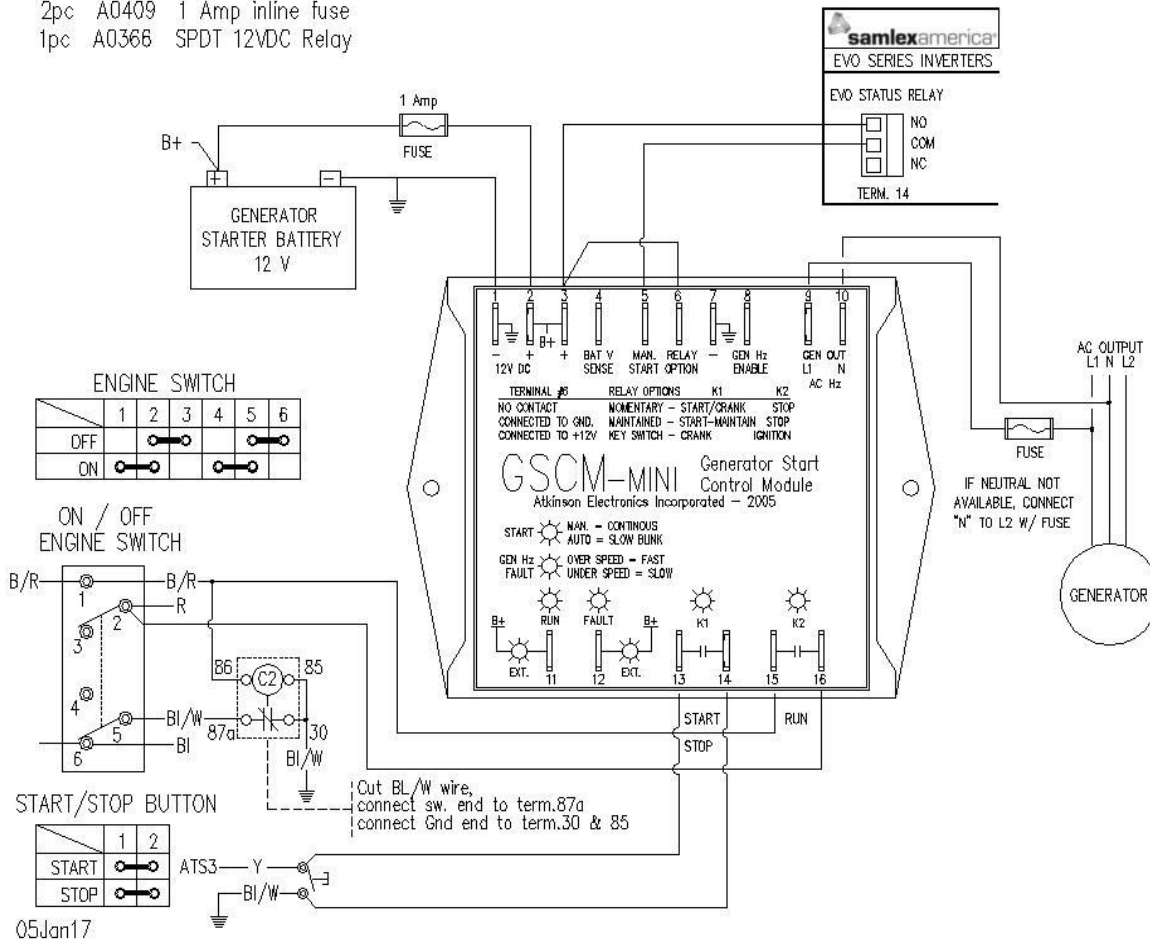

The GSCM-mini-P’s K1 relay contact wire in parallel with the generators Start/Stop push button. It’s K2 relay contact wires to engine switch terminal 1 & 2 and a control relay (C2) terminals 85 & 86, C2’s normally closed (87a) and common (30) tabs, wires in series with the ground wire that connects to terminal 5 of the engine switch, when not energized, it grounds the ignition coil. Engine switch to be left in the OFF position.

The GSCM-mini-P’s terminal #6 is connected to terminal #3 (+12vdc) and to Samlex’s normally open relay contact, and the common contact wires back to terminal #5 on the GSCM-mini-P. The generators AC output is wired to terminals # 9 & 10 providing the run feedback signal. An optional Battery tender/charger is not needed for this option.

The GSCM-mini-P accepts Samlex’s two wire relay contact (maintained run signal) and provides a one second start /stop pulse as outlined on page 6 GSCM-mini-P option#2.

If a battery tender/charger is used, the engine switch should be left in the ON position and the C2 control relay is not used.



### Westinghouse WGen7500DF Generator

- Items needed:  
 1pc A0227 GSCM-mini-P  
 2pc A0409 1 Amp inline fuse  
 1pc A0366 SPDT 12VDC Relay

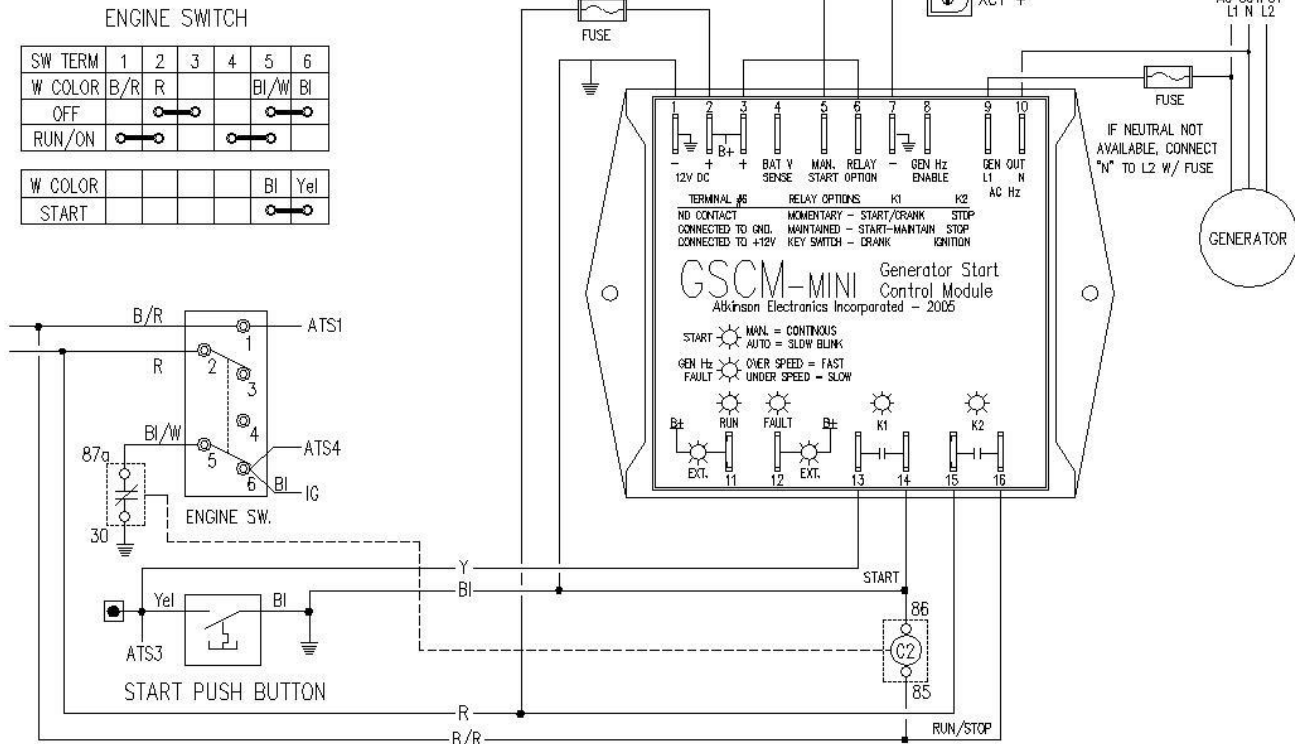

21Jan2020 THE ENGINE SWITCH IS LEFT THE 'OFF' POSITION, THE GSCM-MINI IS CONFIGURED FOR KEY SWITCH OPTION, WHEN A START REQUEST IS RECEIVED GSCM ENERGIZES C2 WHICH OPENS THE GROUND CONNECTION TO THE ENGINE SWITCH ALLOWING THE ENGINE TO START.

The GSCM-mini-P's K1 relay contact wire in parallel with the generators Start/Stop push button. It's K2 relay contact wires to engine switch terminal 1 & 2 and a control relay (C2) terminals 85 & 86, C2's normally closed (87a) and common (30) tabs, wires in series with the ground wire that connects to terminal 5 of the engine switch, when not energized, it grounds the ignition coil. Engine switch to be left in the OFF position.

The GSCM-mini-P's terminal #6 is connected to terminal #3 (+12vdc) and Outback's switched 12vdc maintained start/run signal is wired to the GSCM-mini-P's manual start input. Outback's AUX- wires to terminal #7 and AUX+ wires to terminal #5 on the GSCM-mini-P. The generators AC output is wired to terminals # 9 & 10 providing the run feedback signal. An optional Battery tender/charger is not needed for this option.

The GSCM-mini-P accepts Outback's switched 12vdc two wire signal (maintained run signal) and provides a one second start /stop pulse as outlined on page 6 GSCM-mini-P option #2.

If a battery tender/charger is used, the engine switch should be left in the ON position and the C2 control relay is not used.



Westinghouse P9500DF Dual Fuel Generator

Items needed:

1pc A0227 GSCM-mini-P

2pc A0409 1 Amp inline fuse

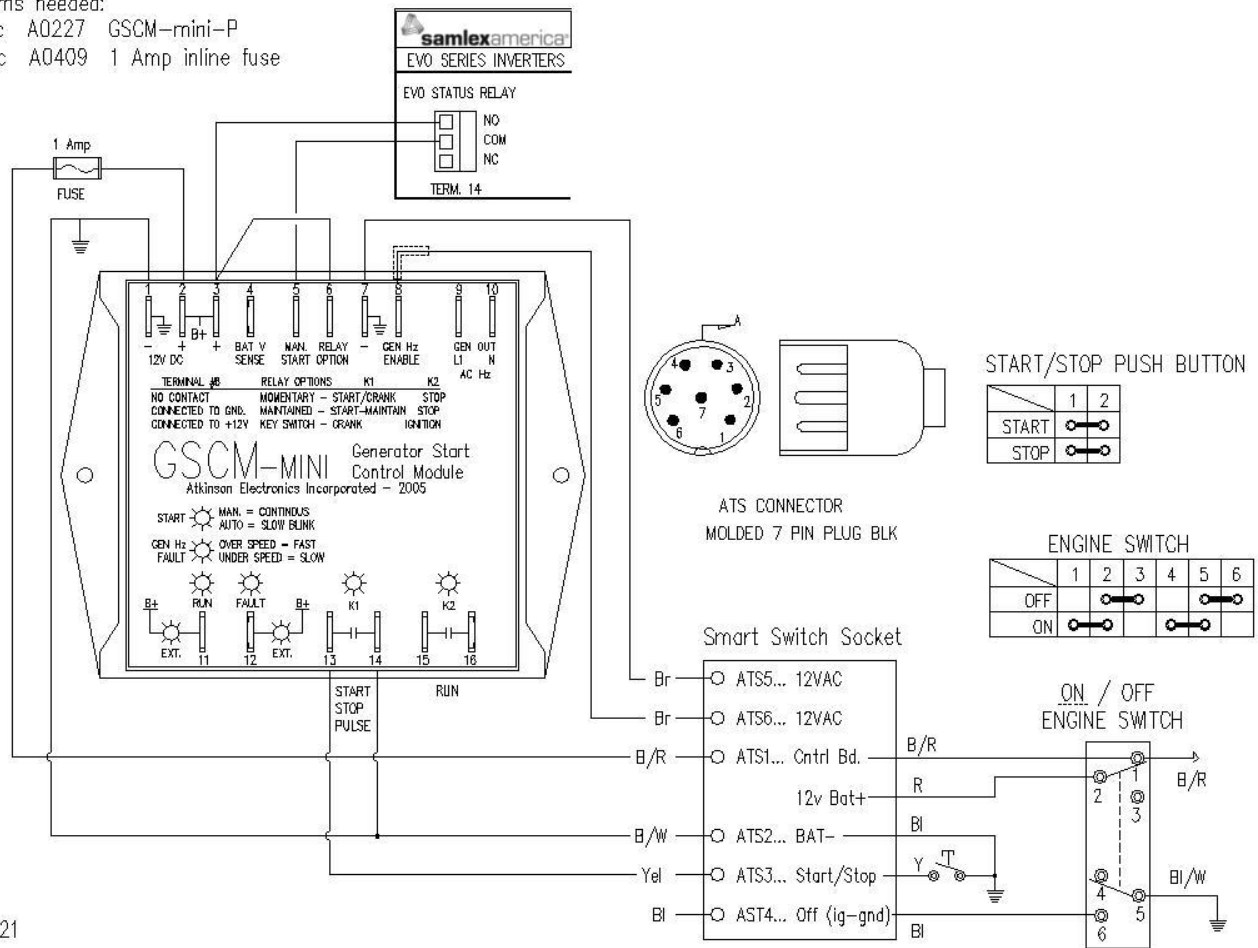

11Jan21

The GSCM-mini-P uses the generator's Remote/ATS connector for all connections to the generator. The GSCM-mini-P's power, relay and run feedback connections use the ATS connector as shown above. The generator's engine switch is left in the ON position. This allows the GSCM-mini-P to start and stop the generator without an additional control relay. A battery tender/charger is used to keep the battery from discharging due to the engine switch being left on 24/7.

The GSCM-mini-P's terminal #6 is connected to terminal #3 (+12vdc) and to Samlex's normally open relay contact, and the common contact wires back to terminal #5 on the GSCM-mini-P. The generator's DC output is wired to terminals #7 & 8 providing the run feedback signal. An optional Battery tender/charger is not needed for this option.

The GSCM-mini-P accepts Samlex's two wire relay contact (maintained run signal) and provides a one second start /stop pulse as outlined on page 6 GSCM-mini-P option#2.





Duramax XP13000EH Dual Fuel Generator

Items needed:

- 1pc A0227 GSCM-mini-Pulse
- 2pc A0409 1 Amp inline fuse
- 1pc A0365 SPST 12VDC Relay

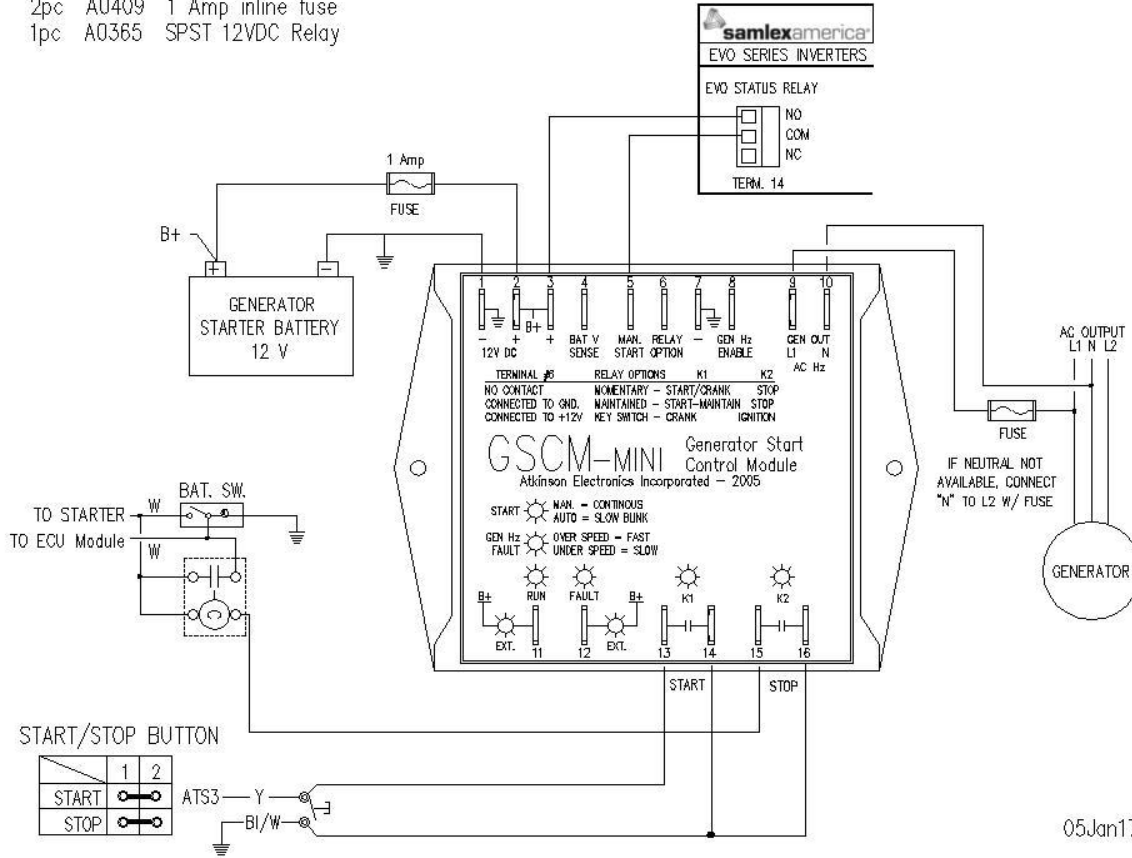

05Jan17

The GSCM-mini-P's K1 relay contact wire in parallel with the generators Start/Stop push button. The mini-P's K2 relay contact wires to a control relay that bypasses the generators power switch. The GSCM-mini-P's terminal 15 wires to one side of the relay coil (85) the other side of the coil (86) connects to the normally open contact (87) and to the white wire that connects to the power switch and the starter motor. The relay contact common (30) connects to the ECU 's white wire that connects to the switch. The generators power switch should remain in the OFF position.

The GSCM-mini-P's terminal #6 is not connected to either terminal #3 or #7. Terminal 3 (+12vdc) is connected to Samlex's normally open relay contact, and the common contact wires back to terminal #5 on the GSCM-mini-P. The generators AC output is wired to terminals # 9 & 10 providing the run feedback signal. An optional Battery tender/charger is not needed for this option.

The GSCM-mini-P accepts Samlex's two wire relay contact (maintained run signal) and provides a one second start /stop pulse as outlined on page 7 GSCM-mini-P option#3.



Atkinson Electronics, Inc. gives this express warranty (along with extended warranty endorsements, where applicable) in lieu of all other warranties, express or implied, including (without limitation), warranties of merchantability and fitness for a particular purpose. This constitutes Atkinson Electronics, Inc.'s sole warranty and obligation with regard to our products as well as the Customer's sole remedy.

Atkinson Electronics, Inc. expressly disclaims all liability and responsibility for any special, indirect or consequential damages or any further loss of any kind whatsoever resulting from the use of our product. The Customer's sole and exclusive remedy and the limit of Atkinson Electronics, Inc.'s liability for any loss whatsoever, shall not exceed the purchase price paid by the Customer for the product to which a claim is made.

Countries or States that do not allow limitations of incidental or consequential damages or on how long an implied warranty lasts, the above limitations may not apply to you. This warranty gives you specific legal rights and you may also have other rights which vary from State to State or Country to Country.

All products manufactured by Atkinson Electronics, Inc. are warranted to be free from defects in material and workmanship in accordance with and subject to the following terms and conditions:

1. This warranty is limited to the original customer only. It cannot be transferred or assigned to third parties unless the intent to transfer to a third party is expressly indicated in a purchase order and/or warranty processing arrangements have been agreed upon in writing by Atkinson Electronics, Inc.
2. Atkinson Electronics, Inc. will correct any defects in material or workmanship which appear within two (2) years from the date of shipment by Atkinson Electronics, Inc. (or its authorized distributors) to the original Customer. Atkinson Electronics, Inc. will repair or replace, at our option, any defective products, provided that our inspection discloses that such defects developed under normal and proper use. This warranty does not extend to goods subjected to misuse, neglect, accident or improper installation, or to maintenance or repair of products which have been altered or repaired by anyone except Atkinson Electronics, Inc., unless otherwise stated in writing. Atkinson Electronics, Inc. will correct any defects in material or workmanship of OEM products (designated as such in our catalog or web site) which appear within two (2) years from the product date code or from the factory invoice date, whichever is later.
3. An appropriate charge (25% of product list price) may be made for testing, repairs, replacement and shipping for a returned product which is not defective or found to be defective as the result of improper use, maintenance or neglect.
4. Atkinson Electronics, Inc. will not accept responsibility for any invoiced goods or services that are not covered by an Atkinson Electronics, Inc. written purchase order. Under no circumstances does Atkinson Electronics, Inc. agree to pay for labor or other related expenses associated with the troubleshooting and/or repair of our product without prior specific written authorization.
5. Information in our descriptive literature is based on product specifications that are current at the time of publication.

Product specifications, design and descriptive literature are subject to change as improvements are introduced. Although we announce changes as they occur, we cannot guarantee notification to every Customer. Atkinson Electronics, Inc. warrants delivered products to conform to the most current specifications, design and descriptive literature. This warranty policy may be expanded or limited, for particular categories of products or customers, by information sheets published as deemed appropriate by Atkinson Electronics, Inc.

