

Installation Guide

Mounting

The unit may be mounted in any position but typically is installed on a vertical surface with the pressure ports on the right and the cable entrance on the left. Avoid locations with severe vibrations or excessive moisture. The enclosure has a standard 1/2-inch conduit opening and may be installed with either a conduit coupler or a cable-gland-type fitting.

1. Ensure there is enough space around the unit to make the pressure and electrical connections.
2. Cut a 5/8-inch hole in the duct.
3. Insert with probe opening facing into the airflow.
4. Use screws threaded through the case's mounting holes to fasten the assembly to the duct. Do not overtighten.

⚠ WARNING

Do not use in explosive or hazardous environments, with combustible or flammable gasses, as a safety or emergency stop device, or in any other application where failure of the product could result in personal injury.

⚠ CAUTION

Use electrostatic discharge precautions during installation. Do not exceed the device ratings.

Plumbing

The output signal reads a positive value when the port pressure is higher on the High port (the attached probe) than the Low port.

Run a return line from the Low port to the vicinity of the point being measured. Do not leave the Low port open to the atmosphere or inaccurate measurements may result. Use clean, new, 0.170-inch I.D. flexible tubing for the Low pressure connection. Arrange the tubing to minimize stress on the connections and prevent kinking.

⚠ CAUTION

Do not allow debris to fall into the pressure ports. Contamination can damage sensor.

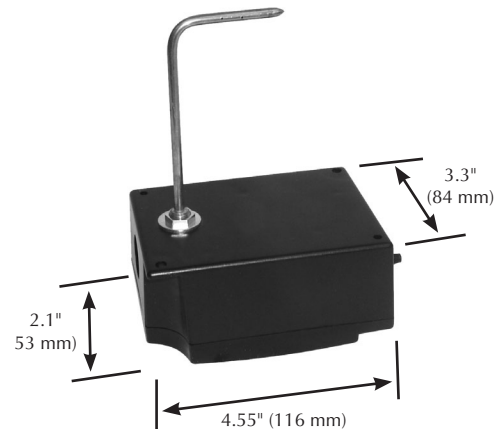

Wiring

Use at least 22 AWG, shielded, twisted-pair wiring for all connections. Do not locate device wires in the same conduit with wires supplying inductive loads.

1. Connect the positive DC voltage or the hot side of the AC voltage to the terminal marked **PWR**.
2. Connect the power supply common to the appropriate terminal according to the application. (See diagrams on the next page.) This device is reverse-voltage protected and will not operate if connected backwards.

The analog output signal is available on the **OUT** terminal. This signal is jumper-selectable for either voltage or 4–20 mA output. In voltage mode, either 0–5 or 0–10 VDC can also be selected.

The detectors have a half-wave type power supply. The power supply common is the same as the output signal common. Therefore, several units may be connected to one power supply and the output signals will share the same signal common.

The analog output signal is typically connected directly to the Building Automation System and used as a control parameter or for logging purposes.

⚠ CAUTION

When grounding the secondary of an AC transformer or when wiring multiple devices, ensure that the circuit ground point is the same on all devices and the controller.

For (obsolete) models 1476-10, 1476-11, 1476-12 only

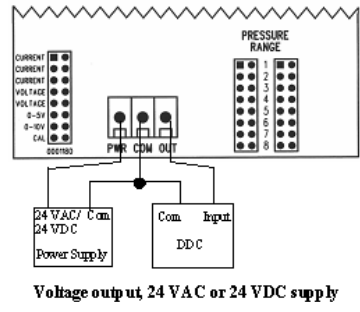
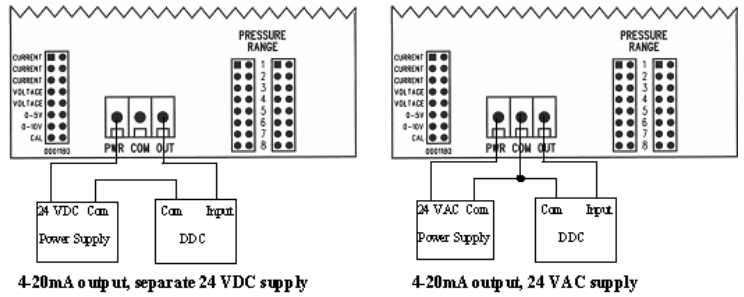
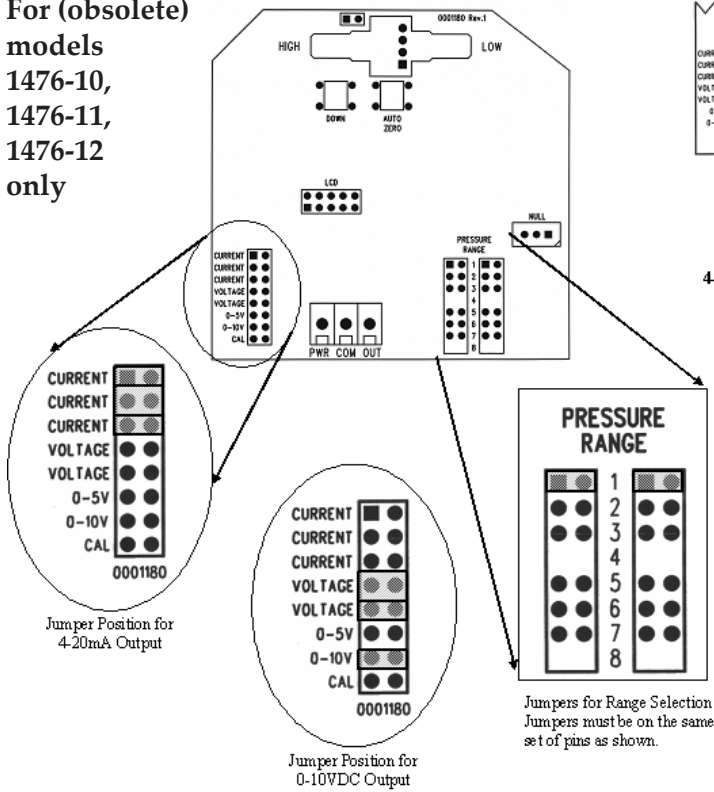

NOTE: CAL position for factory use only

For models 1476-21, 1476-22, 1476-23, 1476-24 BEFORE model year 2011 only

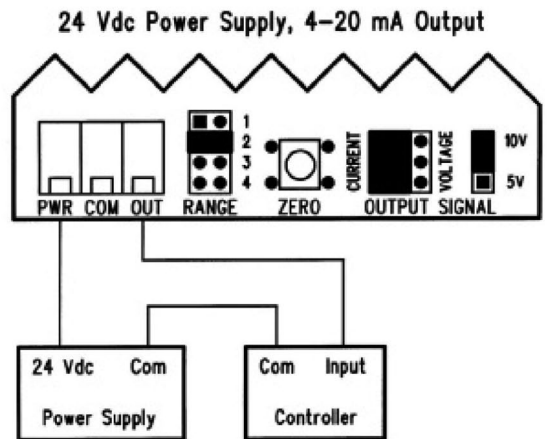
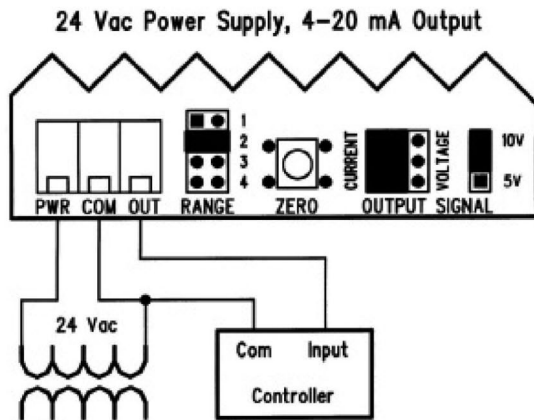
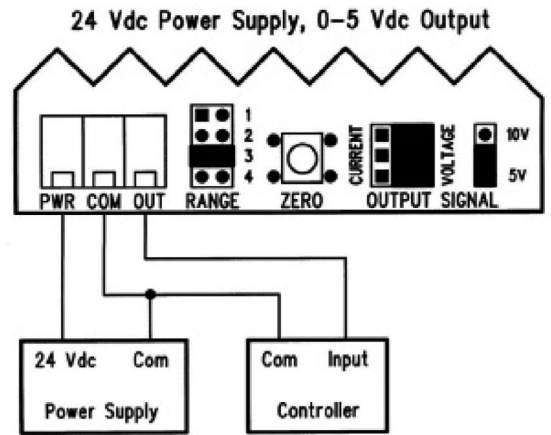
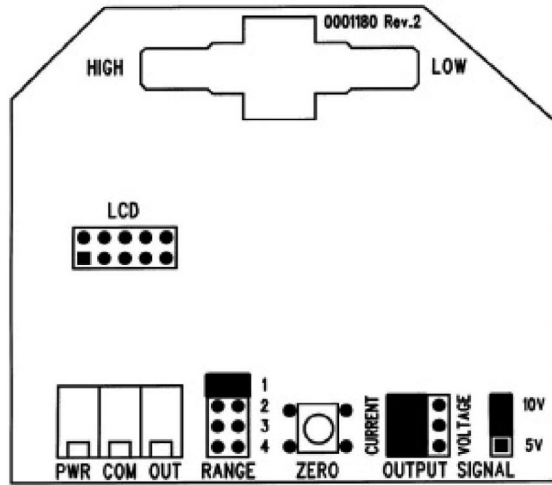

For models 476-21, 1476-22, 1476-23, 1476-24 model year 2011 and after

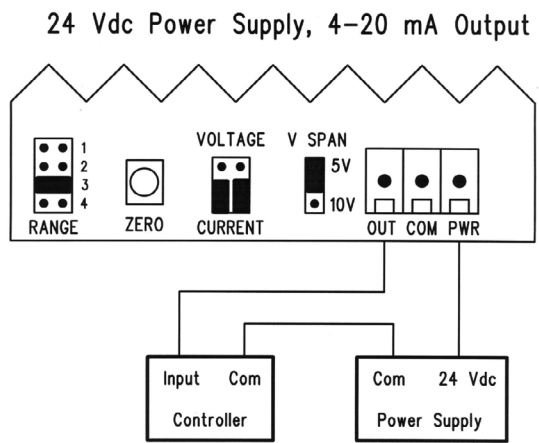
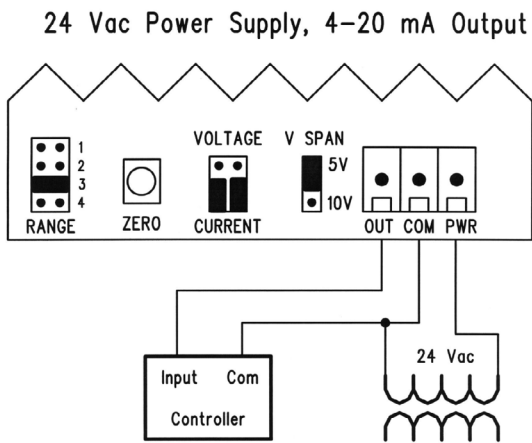
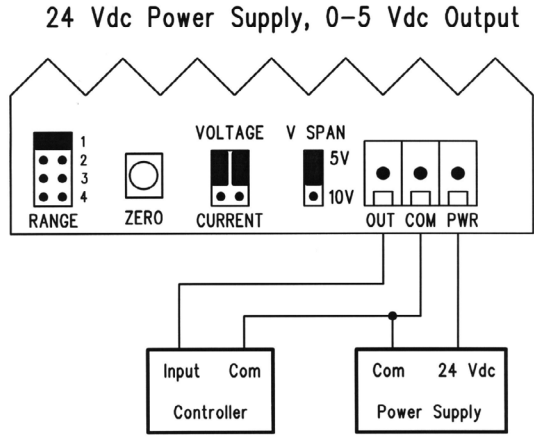
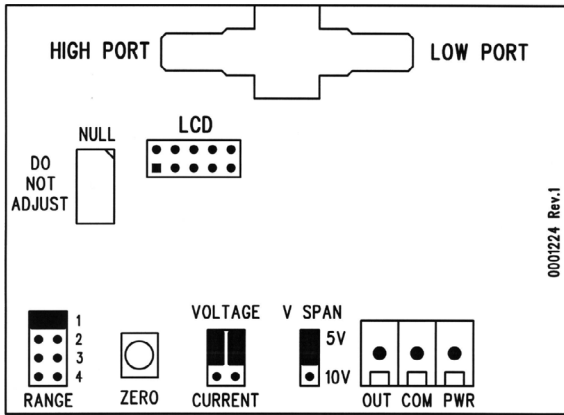

Setting-up and Operating

Configuration

Jumpers are used to select the output signal type and the input pressure range. The device is factory configured to operate in the 4–20 mA output mode but can be changed to voltage mode by moving the jumpers from the positions marked “**Current**” to the positions marked “**Voltage**.”

▲ CAUTION

Carefully note the existing jumper orientation before moving them to the new position. If the jumpers are rotated 90 degrees and installed incorrectly, the product will not work and damage may occur.

Range

For (obsolete) 1476-10/1476-11/1476-12 models, the input pressure range is set by moving two jumpers to the appropriate range. The available ranges are marked 1–8 on the circuit board. The two jumpers must be set to the same range or incorrect readings will result.

For 1476-21/1476-22/1476-23/1476-24 models, the input pressure range is set by moving one jumper to the appropriate range. The available ranges are marked 1–4 on the circuit board.

▲ CAUTION

Check that all connections and jumpers are correct before applying power to the transmitter.

Power-up

The unit should be allowed to warm-up for several minutes before attempting to verify the device accuracy or adjust the null offset. It is best to allow the transmitter to operate for 1 hour before any adjustment or calibration is performed.

Proper operation can be verified by measuring the output signal. For voltage output configuration, measure the voltage between the OUT and COM terminals. The voltmeter should read between 0 to 5 VDC or 0 to 10 VDC, depending on the output range selected. For current output configuration, insert a mA meter in series with the OUT terminal. The mA meter should read between 4 and 20 mA.

Calibration

All pressure ranges are factory calibrated and no calibration is necessary. The user may adjust the zero point if desired when changing ranges. Make sure the unit is warmed up for at least 10 minutes (1 hour is best) before making a zero adjustment.

With both ports open to the ambient pressure, press and hold the Zero (or Auto-Zero) button for **at least 3 seconds**. Release the Zero button after at least 3 seconds. The device will calculate and store the new zero point.

It is not recommended that the span calibration be performed in the field unless a high-quality calibrator with low differential pressure ranges is available and the temperature of the sensor can be maintained. Contact the factory for information on this type of calibration.

Jumper Setting	Pressure Range						
	1476-10*	1476-11*	1476-12*	1476-21	1476-22	1476-23	1476-24
1	±2" wc	±6" wc	±1000 Pa	*	±1.5" wc	±2.5" wc	±250 Pa
2	±1" wc	±3" wc	±500 Pa	±1" wc	±3" wc	±5" wc	±500 Pa
3	±0.5" wc	±1.5" wc	±250 Pa	*	0 to 3" wc	0 to 5" wc	0 to 500 Pa
4	n/a			0 to 2" wc	0 to 6" wc	0 to 10" wc	0 to 1000 Pa
5	0 to 4" wc	0 to 12" wc	2000 Pa	n/a			
6	0 to 2" wc	0 to 6" wc	1000 Pa				
7	0 to 1" wc	0 to 3" wc	500 Pa				
8	n/a						

*NOTE: The former ±0.5" and 0 to 1" settings have been derated from the TPE-1476-21. Models 1476-10, 1476-11, and 1476-12 have been discontinued.

Operation

If the TPE-1476 is set to a **unipolar** range, such as 0 to 2" wc, then the pressure applied to the **High** port must be higher than the pressure applied to the **Low** port. If the **Low** port is left open to ambient pressure and the **High** port is used to measure a positive pressure, then the output pressure can be calculated using the following formulas:

4–20 mA:

$$\text{Pressure} = \frac{[(\text{Output current} - 4 \text{ mA}) / 16 \text{ mA}] \times \text{Range}}$$

0–5 VDC:

$$\text{Pressure} = (\text{Output voltage} / 5 \text{ V}) \times \text{Range}$$

0–10 VDC:

$$\text{Pressure} = (\text{Output voltage} / 10 \text{ V}) \times \text{Range}$$

With 0–2" wc, for example, 4 mA or 0 V = 0" wc and 20 mA or 5 V or 10 V = 2" wc. Since the transmitter is linear, 1" wc would be 12 mA or 2.5 V or 5 V.

NOTE: If the positive pressure connection is reversed, the transmitter will always output 4 mA or 0 V.

If the TPE-1476 is set to a **bipolar** range, such as ±2" wc, then the pressure applied to the **High** port should be higher than the pressure applied to the **Low** port for a positive output response. In this case, differential pressure can be measured using both ports. If the **High** port has a positive pressure with respect to the **Low** port, then the output indicates a positive pressure. Negative pressure is indicated if the **High** pressure is less than the **Low** pressure. For bipolar ranges, the output pressure can be calculated as follows:

4–20 mA:

$$\text{Pressure} = \frac{[(\text{Output current} - 4 \text{ mA}) / 16 \text{ mA}] \times 2 \times \text{Range} - \text{Offset}}$$

0–5 VDC:

$$\text{Pressure} = (\text{Output voltage} / 5 \text{ V}) \times 2 \times \text{Range} - \text{Offset}$$

0–10 VDC:

$$\text{Pressure} = (\text{Output voltage} / 10 \text{ V}) \times 2 \times \text{Range} - \text{Offset}$$

With ±2" wc, for example, 4 mA or 0 V = –2" wc and 20 mA or 5 V or 10 V = +2" wc. Since the transmitter is linear, 0" wc would be 12 mA or 2.5 V or 5 V.

Key Specifications

(See Data Sheet for full specifications list.)

Output Signal Options

4–20 mA (2-wire)

0–5 VDC or 0–10 VDC (3-wire)

Current Output Drive Capability

400 ohm maximum @ 24 VDC

Voltage Output Drive Capability

2K ohm minimum for 0–5

VDC signal

10K ohm minimum for 0–10

VDC signal

Power Supply (at transmitter)

12 to 28 VAC, 16.5 to 35 VDC
(non-isolated half-wave rectified)

Supply Current

< 4 mA

Protection Circuitry

Reverse voltage protected and output limited

Wiring Connections

Screw terminal block (14 to 22 AWG)

Zero Adjustment

Push-button auto-zero

Operating Conditions

32° to 140° F (0° to 60° C), 10 to 90% RH non-condensing

Media Compatibility

Limited only to those that will not attack polyetherimide, silicon, fluorosilicone, silicone, EPDM, and neoprene seals; typically, dry air or inert gas but liquid is allowed

Maintenance

No routine maintenance is required. Each component is designed for dependable, long-term reliability, and performance. Careful installation will also ensure long-term reliability and performance.

KMC Controls, Inc.

19476 Industrial Drive

New Paris, IN 46553

574.831.5250

www.kmcccontrols.com

info@kmcccontrols.com