

Installation Guide

(Snap Track) Mounting

The transducers may be mounted in any position.

1. Carefully remove the circuit board from the Snap Track.
2. Mount the track in the desired location.
3. Replace board in the track. Do not slide or flex the circuit board while replacing.

Connections

A clean, dry, oil-free main air supply is required for proper operation. An internal, non-replaceable filter is used. If air supply contamination is suspected, use an external HFO-0006 in-line filter.

The gauge port will accept a 1/8" male NPT pressure gauge. This allows direct reading of the pressure output. This port must be plugged if a pressure gauge is not required.

1. Connect the 20 psi main air to the "M" port.
2. Connect the "B" port to the controlled device (damper or valve actuator).

Wiring

1. Connect the power.
 - a. 24 VAC (+20%/–15%, 1 VA):
 - Transformer phase lead to "~" (phase).
 - Neutral lead to "GND" (common).
 - b. 24 VDC (+66%/–8%, 50 mA):
 - Positive to "~" (phase).
 - Negative to "GND."

NOTE: Any device connected to this transformer must use the same common. If you are not sure of the other device's polarity, use a separate transformer. If the shared device is a coil, use a spike-snubbing device across the coil to prevent possible malfunctions.

2. Position Input Program Jumper to 1–5 VDC, 2–10 VDC, or 4–10 mA.
3. Connect the input signal wiring, positive to "IN" and negative to "GND."
4. Connect the output feedback signal (if required) positive to "OUT 1–5" and negative to "GND."

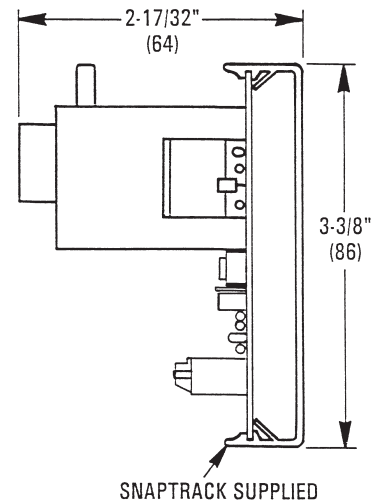
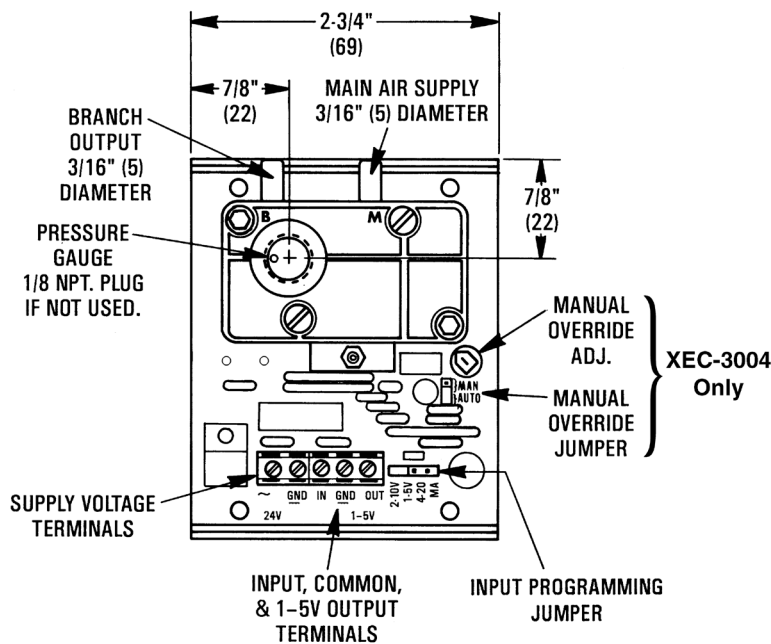

Adjustments

Manual Override (XEC-3004 Only)

1. Move the "MAN/AUTO" jumper from "AUTO" to "MAN." (See the illustration on page 1.)
2. Adjust the potentiometer for desired output by observing gauge or the 1–5 VDC output signal.

Span and Zero

The "Span and "Zero" adjustments are factory-set and should never need adjusting. On boards manufactured **before Nov. 2009** (only), this calibration may be adjusted slightly as follows:

1. Disconnect the main air.
2. Adjust the "ZERO" potentiometer to 0.1 VDC feedback output.
3. Reconnect the main air.
4. Apply an input voltage of 5.1 or 10.2 VDC or input current of 20.4 mA.
5. Adjust the "SPAN" potentiometer for 15 psi branch output pressure.
6. Apply an input voltage of 3 or 6 VDC or input current of 12 mA.
7. Readjust the "ZERO" potentiometer for 9 psi.

**Boards Before
Nov. 2009
Only**

SPAN ADJ.
ZERO ADJ.

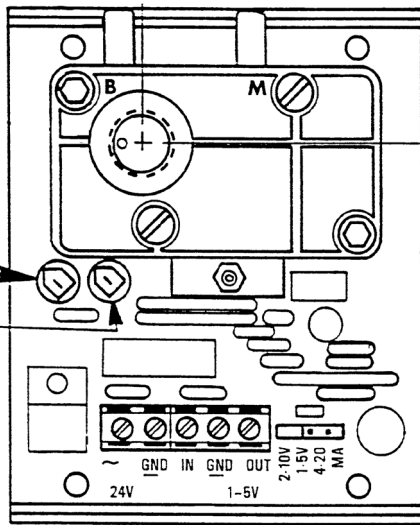

Maintenance

No routine maintenance is required. Each component is designed for dependable, long-term reliability, and performance. Careful installation will also ensure long-term reliability and performance.

⚠ CAUTION

Pneumatic devices must be supplied with clean, dry control air. Any other medium (e.g., oil or moisture contamination) will cause the device to fail.

Models

XEC-3001	Module only
XEC-3002	Module mounted in an HCO-1008 enclosure (not shown)
XEC-3004	Module only with manual override

Accessories

HCO-1008	Enclosure (for XEC-3001/3004)
HFO-0006	In-line air filter
ICI-1005	2", 0–30 psi gauge

For **other pneumatic accessories**, such as connectors, tubing, fittings, filters, and gauges, see the Compressed Air Accessories section in the Electronic and Pneumatic Controls Condensed Catalog (SP-071).

KMC Controls, Inc.
19476 Industrial Drive
New Paris, IN 46553
574.831.5250
www.kmcccontrols.com
info@kmcccontrols.com