

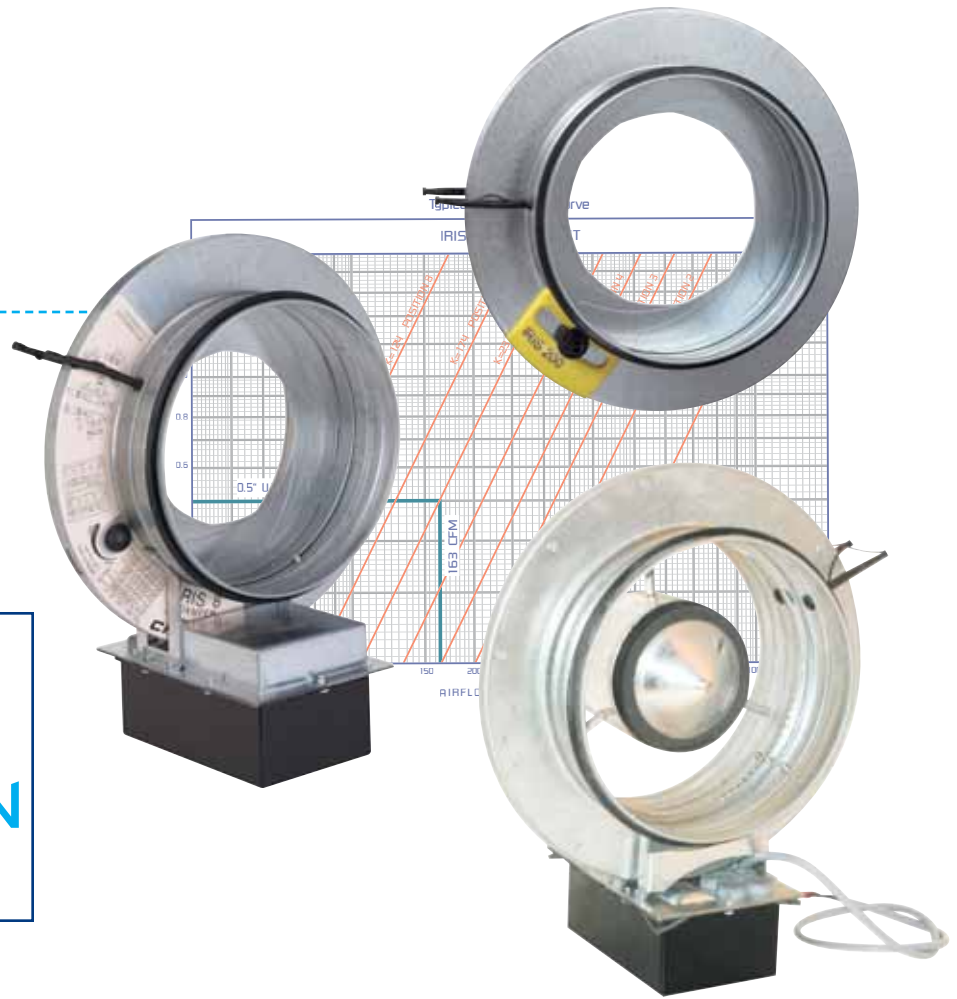

# DAMPERS

*better AIRFLOW  
by DESIGN™*



## IRIS DAMPERS APPLICATION GUIDE

Table of Contents	Page
Principles of Operation .....	2
Application Considerations.....	3
Selection Curves.....	4
IRIS & IRIS-S Dampers .....	6
IRIS-M & IRIS-M-PS Dampers.....	8
IRIS-M Control Examples.....	10
Guide Specifications .....	11

# PRINCIPLES OF OPERATION

## INTRODUCTION

The IRIS damper is a brilliantly simple solution for fast and exact measurement, balance and control of airflow. It is ideal for supply and exhaust tracking control, individual comfort control, and any space requiring accurate airflow regulation. Applications for the IRIS damper include office buildings, pharmaceuticals, clean room environments and laboratories. Its unique design allows for airflow to be measured and controlled at a single station, thus saving time and money in initial installation and commissioning, and those applications requiring air balance on a regular basis.

## CONSTRUCTION

The IRIS damper is comprised of a casing, damper blades, an adjustment or regulating nut, an airflow adjustment chart, and airflow taps. Blades and casing are manufactured from either galvanized (IRIS, IRIS-M) or 316 stainless steel (IRIS-S). The remaining components are made from high strength plastics. On the IRIS-M, an electronic actuator is included to allow for remote control of the damper. The IRIS-M-PS has a positive seal center plug that provides 100% shut-off capability.

## SELECTION

The criteria to be considered when applying an IRIS damper are airflow, pressure drop and sound requirements. The IRIS damper represents a resistance to airflow, as do the duct and fittings.

Selecting an IRIS damper is simple. In the case of an existing duct design, choose an IRIS damper to match duct size.

Alternatively, using the Selection Curves on pages 4 and 5, select an IRIS damper at a mid-range setting to match desired airflow and pressure drop. This establishes the required duct size. Additionally, this provides the end user with balancing flexibility in the event that airflow requirements should change.

Consideration of the total pressure drop and sound requirements at design airflow is important. The Selection Curves indicate the total pressure drop of an IRIS damper at a given airflow and damper position. Additionally, sound pressure curves across various damper settings are provided.  $L_A$  is the sound pressure level with 4 dB room attenuation.

## AIRFLOW CONTROL AND BALANCE

Once an IRIS damper has been selected and installed, and the system is operational, the damper may be adjusted to deliver the required airflow using the airflow adjustment chart located on the damper. Airflow Adjustment Charts for IRIS and IRIS-S dampers are presented on pages 6 and 7. Airflow Adjustment Charts for IRIS-M dampers are presented on page 9.

Each IRIS damper contains two airflow taps (pressure ports) and an airflow adjustment chart. By connecting a pressure gauge to the taps of the damper, the pressure drop across the damper blades can be measured. The illustration (fig.1) shows the setup for making a pressure measurement.

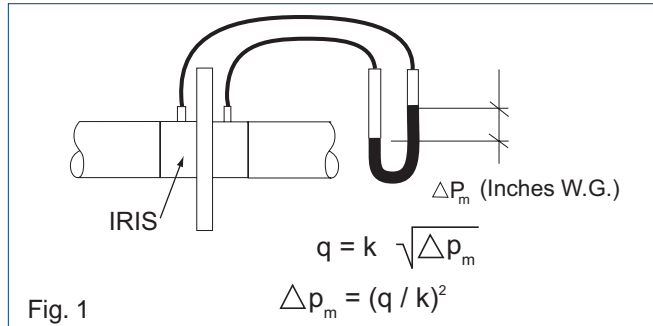

Each damper setting has a unique 'k' factor that defines the curves at different damper settings. The air velocity flowing through the orifice of the damper is proportional to the measured pressure drop. Once the velocity is known, the airflow can be easily calculated when the cross-sectional area of the orifice is known. The relationship between pressure drop and airflow through an IRIS damper is given by the equation:

$$q = k \sqrt{\Delta p_m}$$

where  $q$  = airflow (cfm)  
 $\Delta p_m$  = measured pressure drop (in. w.g.)  
 $k$  = constant of proportionality dependent upon orifice area

For initial airflow balance, note the damper position and related pressure drop. Refer to the Airflow Adjustment Chart to determine the airflow (fig.2).

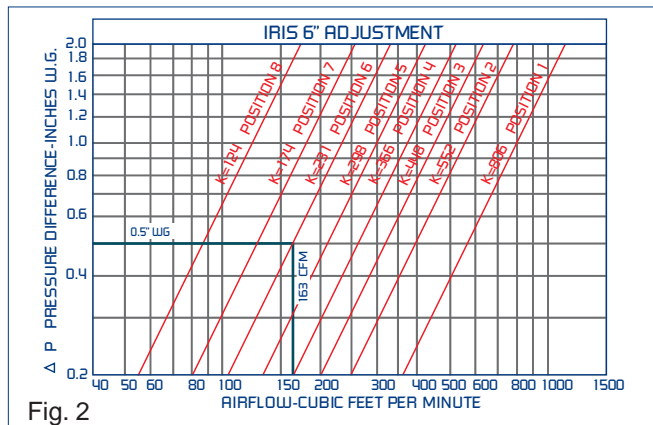

To adjust to a new airflow, locate the desired airflow on the Airflow Adjustment Chart, and adjust the damper position until the required pressure drop is achieved (fig.3).

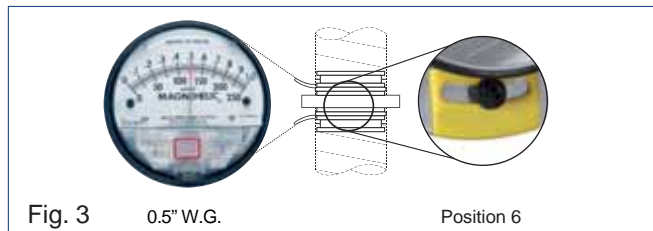

# APPLICATION CONSIDERATIONS

## IRIS DAMPER FEATURES & BENEFITS

- Precise airflow measurement
- Accurate air balancing to +/- 5%
- Single station measurement and control
- Reduced field labor time
- Ideal for office buildings, pharmaceuticals, clean room environments and laboratories
- Compact design, superior performance
- Fully retractable blades for duct cleaning
- Available in an assortment of sizes for a broad range of airflow measurement requirements

## RECOMMENDED INSTALLATIONS

The calibration accuracy of an IRIS damper during disturbance free airflow is 5%. However, when an IRIS damper is installed near duct fittings, measurement accuracy may be affected. For optimum operation and airflow control, the chart (Fig. 4) indicates the recommended distances between an IRIS damper and duct elbows, tees and transitions. From the chart, to achieve the airflow accuracy,  $m_2$ , distance  $L_{min}$  defines the minimum distance separating an IRIS damper from the fitting. For example, when a damper is located at greater than 1 duct diameter from an elbow, the accuracy of the airflow measurement is expected to be  $\pm 7\%$ .

Fig. 4

	$L_{min}$	
	$m_2 = \pm 7\%$	$m_2 = \pm 10\%$
	$\geq 1d$	$\geq 1d$
	$\geq 4d$	$\geq 2d$
	$\geq 2d$	$\geq 2d$
	$\geq 2d$	$\geq 2d$

## MATERIAL SPECIFICATIONS

Product Components	Material
Casing, blades	Galvanized steel or acid-proof steel (AISI 316)
Regulation mechanism	Polyacetal
Stickers, window cover	PVC plastic
Veloduct-sealing	EPDM rubber
Measuring tap	TRP plastic

## ORDERING SPECIFICATIONS

Product	IRIS-04	Size (in.)
IRIS Damper		
IRIS-S Stainless Steel Damper		
IRIS-M Motorized Damper		
IRIS-M-PS Positive Seal Damper		

# SELECTION CURVES

## 4" Damper Selection Curve

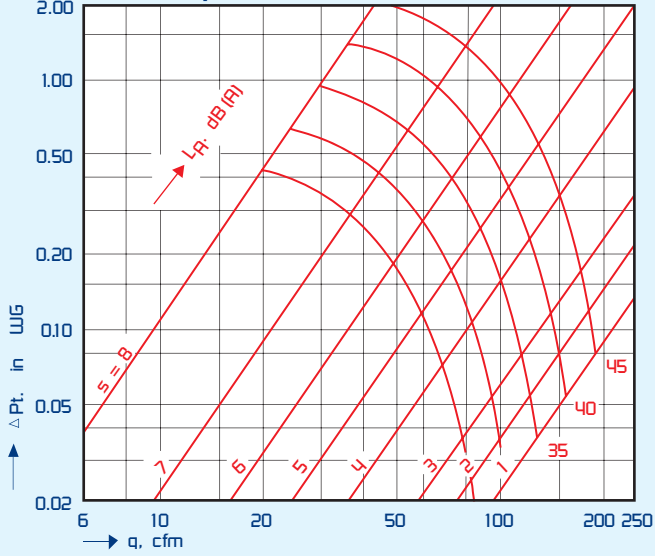

## 5" Damper Selection Curve

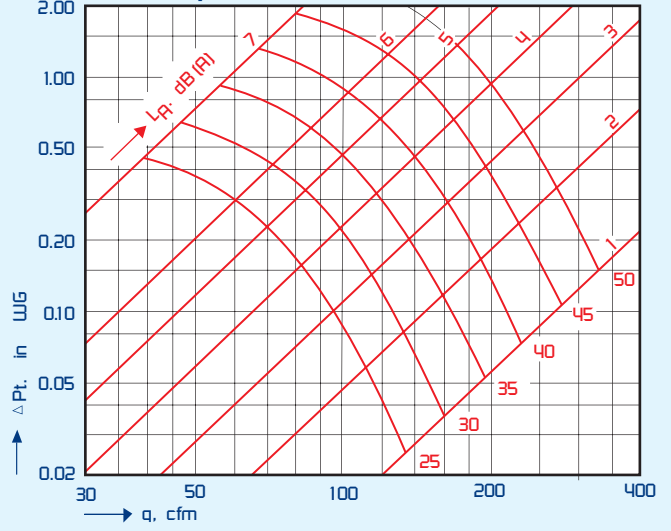

## 6" Damper Selection Curve

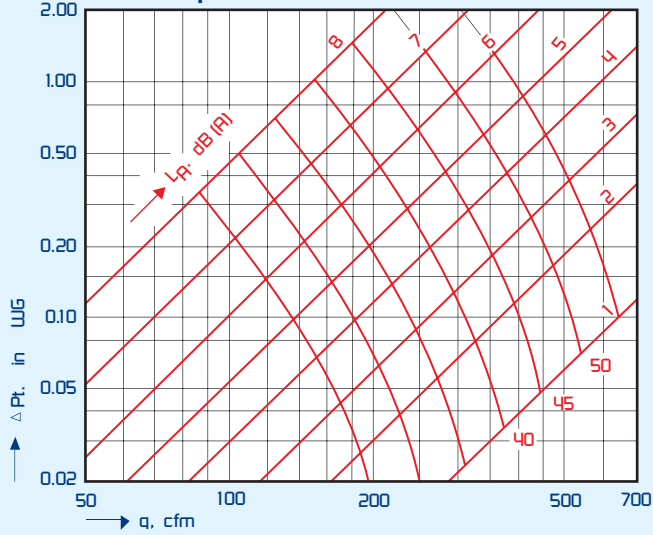

## 8" Damper Selection Curve

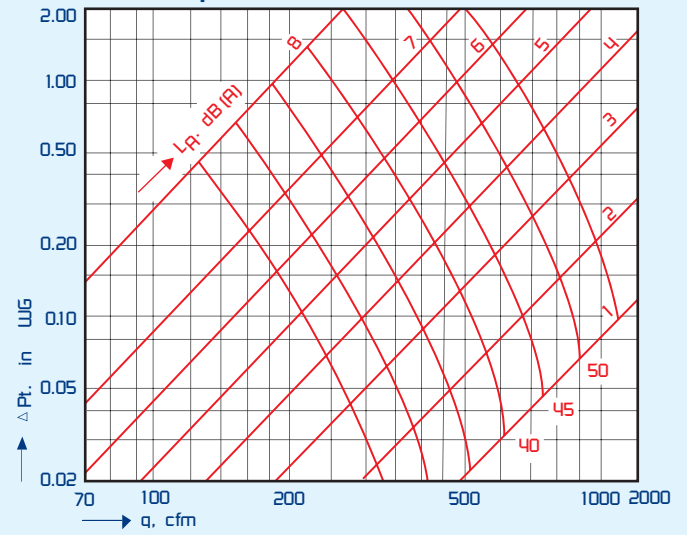

## 10" Damper Selection Curve

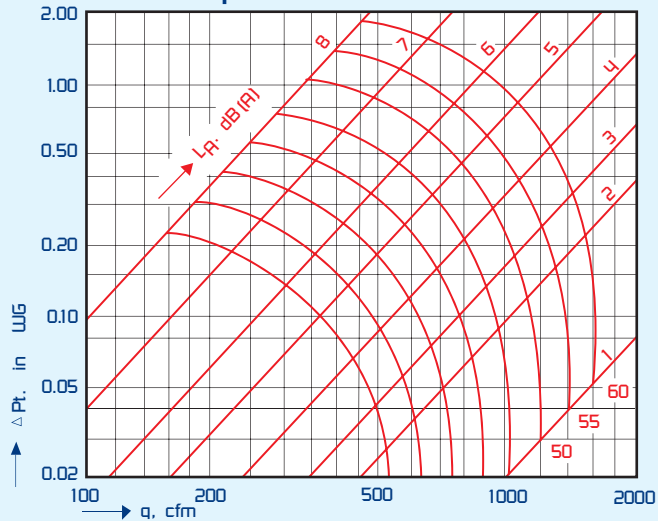

## 12" Damper Selection Curve

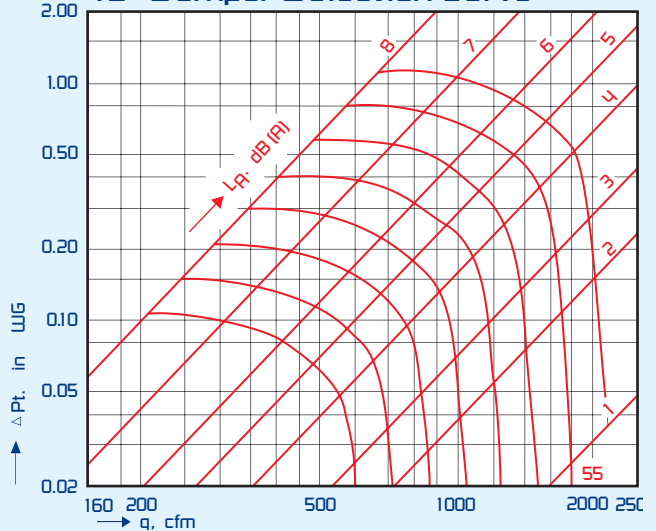

# SELECTION CURVES

## 16" Damper Selection Curve

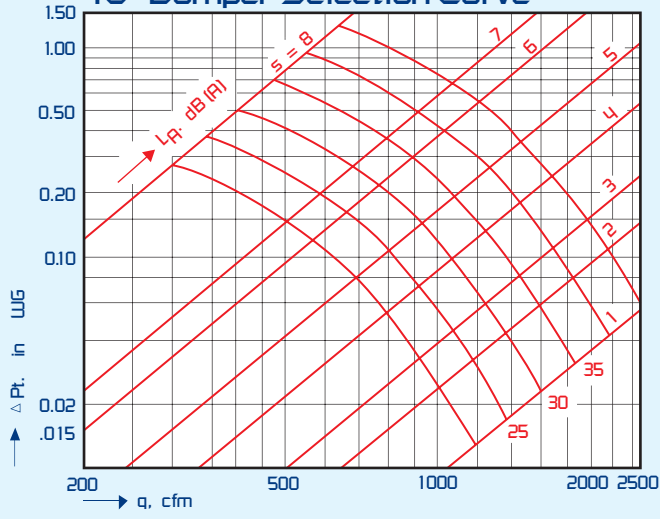

## 20" Damper Selection Curve

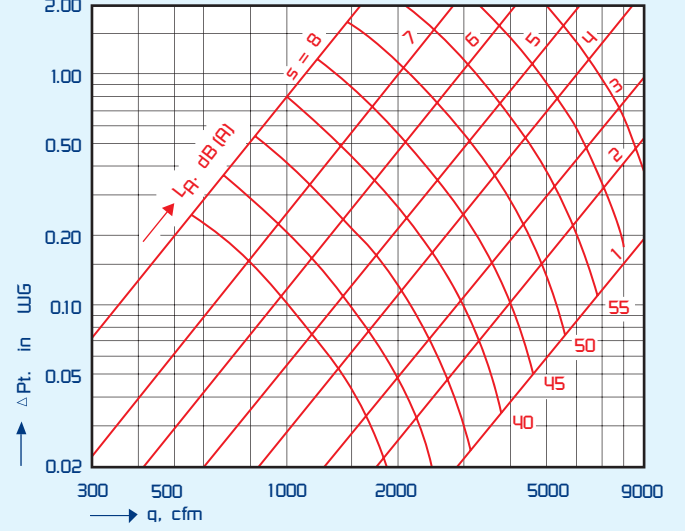

## 25" Damper Selection Curve

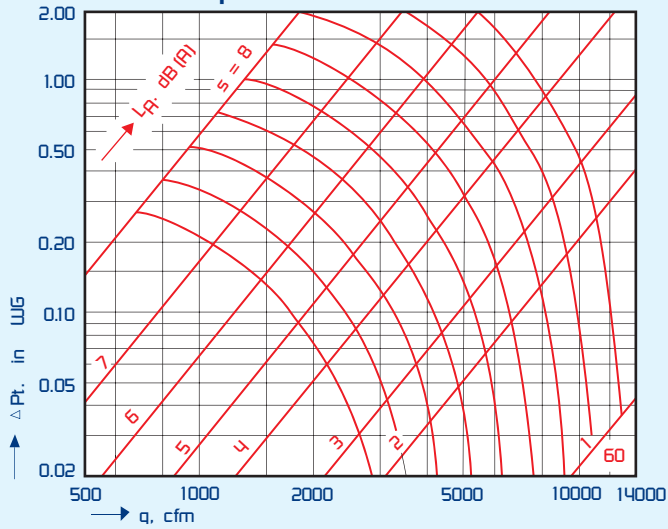

## 32" Damper Selection Curve

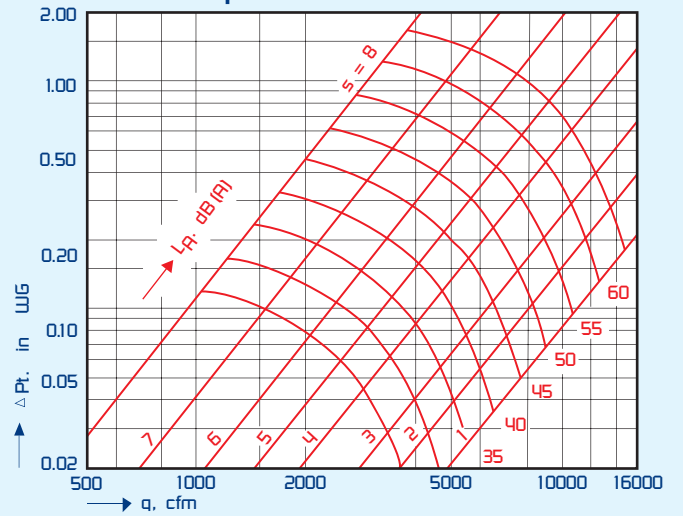

# IRIS & IRIS-S DAMPERS

## IRIS DAMPER

- Single station measurement and control
- Hot dipped galvanized steel construction
- Fitted neoprene gasket for airtight mounting
- Capacities: 15 cfm to 20,000 cfm



## IRIS-S STAINLESS STEEL DAMPER

- AISI 316 stainless steel construction
- Prolonged excellence in extreme conditions
- Ideal for corrosive environments
- Capacities: 15 cfm to 20,000 cfm



## IRIS & IRIS-S DIMENSIONS

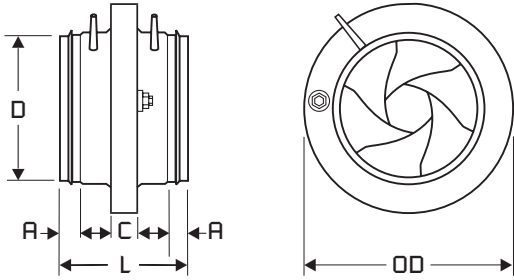

MODEL	DIMENSIONS IN INCHES					
	A	C	D	L	OD	WT(lbs)
IRIS-04, IRIS-S-04	1.2	0.6	3.9	4.6	6.5	1.1
IRIS-05, IRIS-S-05	1.2	0.6	4.9	4.6	7.4	1.5
IRIS-06, IRIS-S-06	1.2	0.6	5.9	4.6	9.1	2.0
IRIS-08, IRIS-S-08	1.2	0.6	7.8	4.6	11.2	3.1
IRIS-10, IRIS-S-10	1.6	0.7	9.8	5.3	13.2	4.6
IRIS-12, IRIS-S-12	1.6	0.7	11.8	6.1	16.1	7.7
IRIS-16, IRIS-S-16	2.4	0.8	15.7	7.5	20.7	14.1
IRIS-20, IRIS-S-20	2.0	0.8	19.6	6.7	25.8	21.2
IRIS-25, IRIS-S-25	2.0	0.9	24.7	6.7	32.1	34.4
IRIS-32, IRIS-S-32	3.9	0.9	31.4	10.6	40.0	55.1

### 4" Damper Adjustment Chart

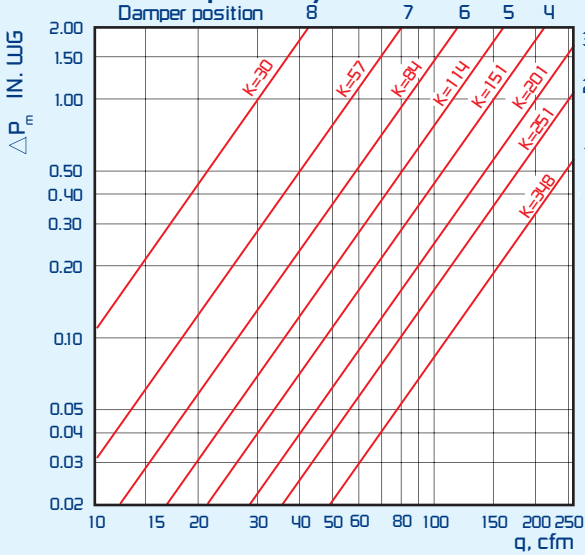

### 5" Damper Adjustment Chart

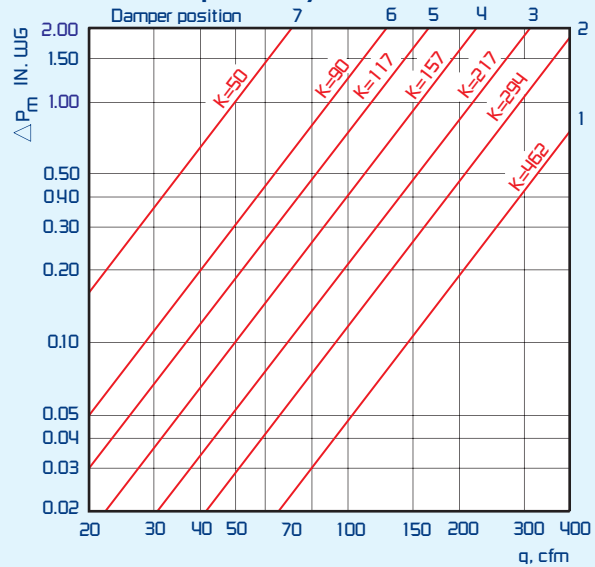

### 6" Damper Adjustment Chart

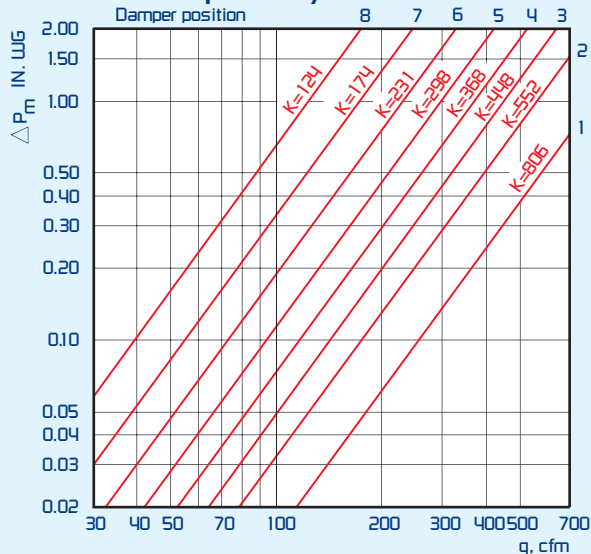

### 8" Damper Adjustment Chart

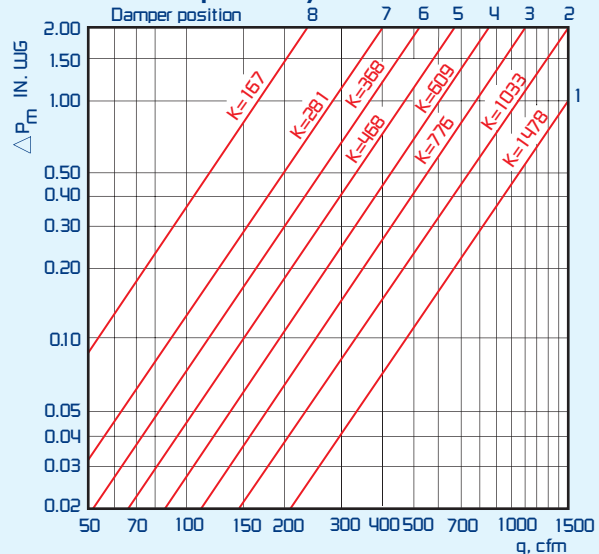

# IRIS & IRIS-5 DAMPERS

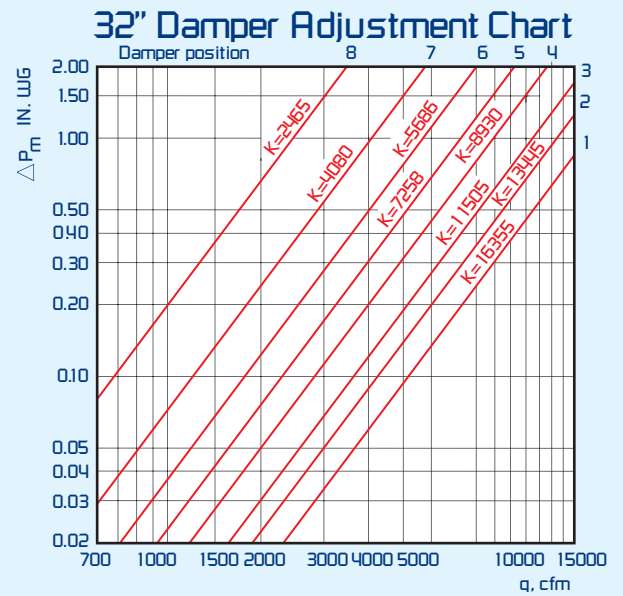
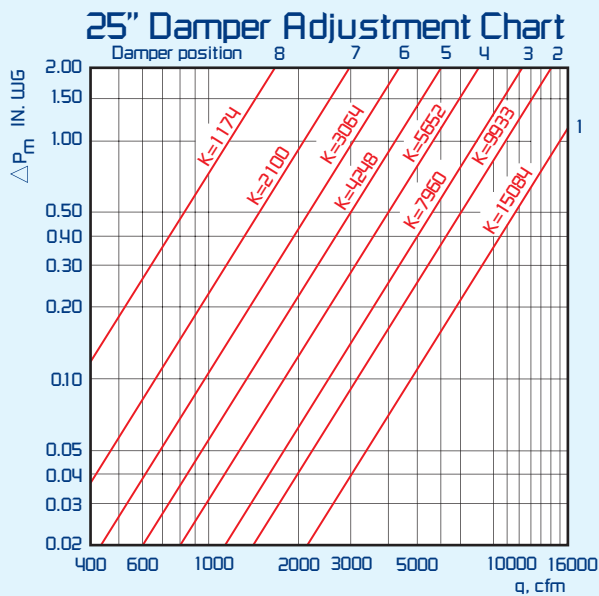
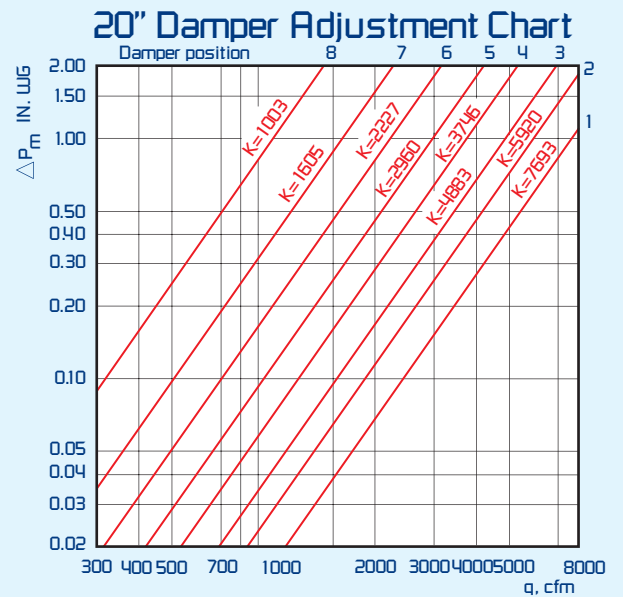
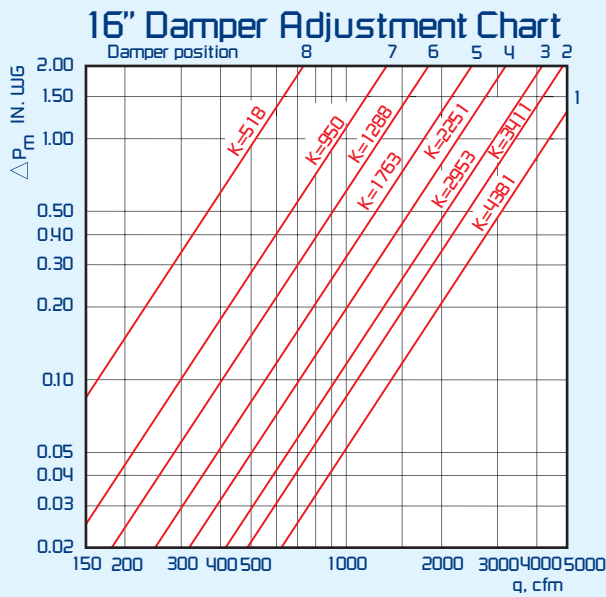
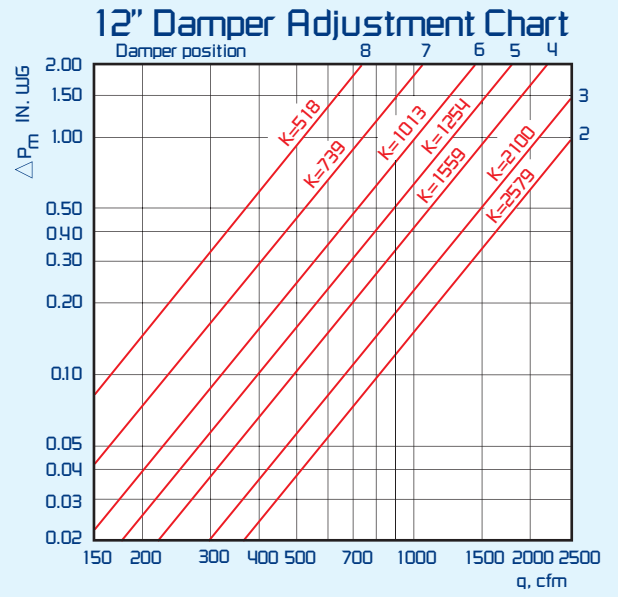
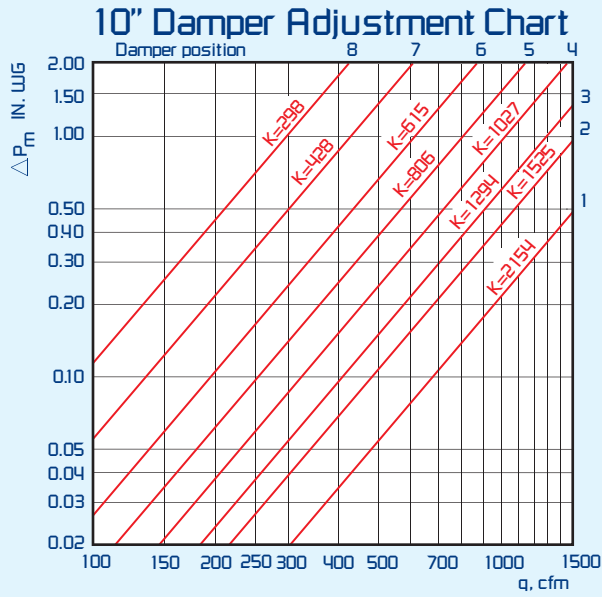

# IRIS-M & IRIS-M-PS DAMPERS

## IRIS-M MOTORIZED DAMPER

- Retracts fully for duct cleaning
- Finger tip control with adjustable set-points
- Interlocking galvanized steel plate construction
- Automatic measurement and control of airflow
- Accepts 0-10 VDC, 2-10 VOC or 4-20 mA signal
- Capacities: 15 cfm to 4,000 cfm



## IRIS-M-PS POSITIVE SEAL DAMPER

- Simple to calibrate min and max settings
- Positive seal with 100% shut-off capability
- Automatic measurement and control of airflow
- Finger tip control with adjustable set-points
- Interlocking galvanized steel plate construction
- Capacities: 15 cfm to 4,000 cfm



## IRIS-M & IRIS-M-PS DIMENSIONS

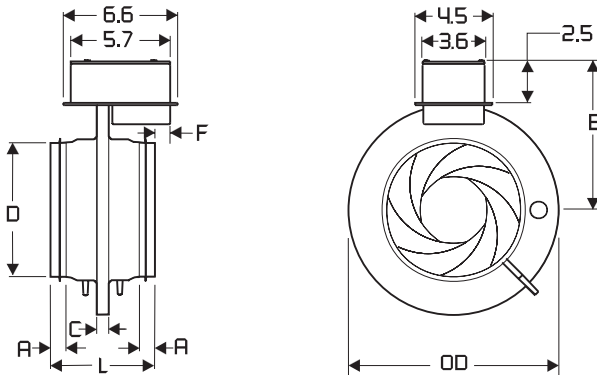

MODEL	DIMENSIONS IN INCHES							
	A	C	D	E	F	L	OD	WT(lbs)*
IRIS-M-04, IRIS-M-PS-04	1.2	0.6	3.9	6.1	1.7	4.6	6.5	4.4
IRIS-M-05	1.2	0.6	4.9	6.6	1.7	4.6	7.4	4.8
IRIS-M-06, IRIS-M-PS-06	1.2	0.6	5.9	7.5	1.6	4.6	9.1	5.3
IRIS-M-08, IRIS-M-PS-08	1.2	0.6	7.8	8.5	1.6	4.6	11.2	6.4
IRIS-M-10, IRIS-M-PS-10	1.6	0.7	9.8	9.4	1.3	5.3	13.2	7.9
IRIS-M-12, IRIS-M-PS-12	1.6	0.7	11.8	10.5	1.0	5.6	16.1	11.0

\* For IRIS-M-PS weight, add 0.5 lbs to IRIS-M.

## DESCRIPTION

The IRIS-M motorized damper assembly provides all the benefits of the standard IRIS damper, plus adds an electronic actuator to allow for remote control of the damper. The IRIS-M is available in six sizes, and permits the damper to be controlled by a building control system, or operate as a standalone unit through the use of switches.

## CONTROL FEATURES

- Accepts 0-10 VDC, 2-10 VDC or 4-20 mA analog inputs
- Adjustable min/max pots for airflow settings
- 2 position or modulating control
- Fully open switch for duct cleaning
- Airflow taps for measuring airflow with either manual gauge or differential pressure transducer
- Multiple actuators may be used in a master/slave arrangement

## ELECTRICAL/CONTROL SPECIFICATION

- 24 VAC Supply Voltage
- Rated Power - 4.5 VA
- Inputs
  - 0-10 VDC
  - 2-10 VDC
  - 4-20 mA
- Actuator Drive Time: 1-3 min.

## IRIS-M WIRING CONNECTIONS

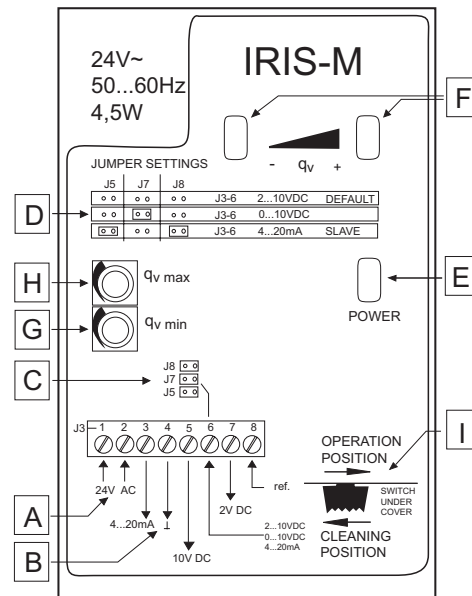

A, B	24 VAC power and input wiring connections
C, D	Input jumpers and instructions
E	Power on/off indicator
F	Min/max flow indicators
G, H	Min/max flow pots
I	Drive open switch



# IRIS-M DAMPERS

## 4" Damper Adjustment Chart

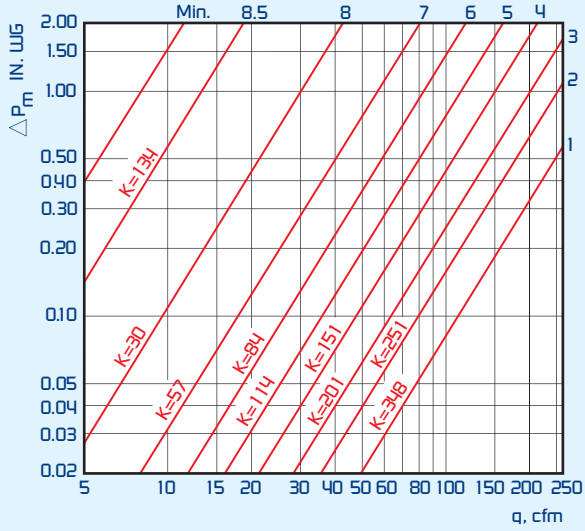

## 5" Damper Adjustment Chart

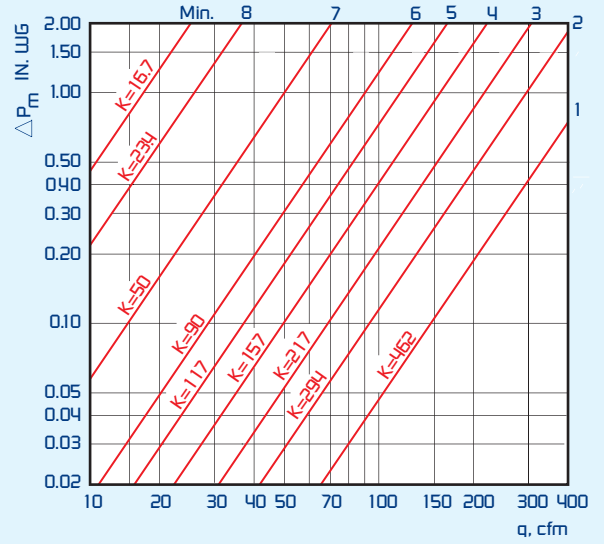

## 6" Damper Adjustment Chart

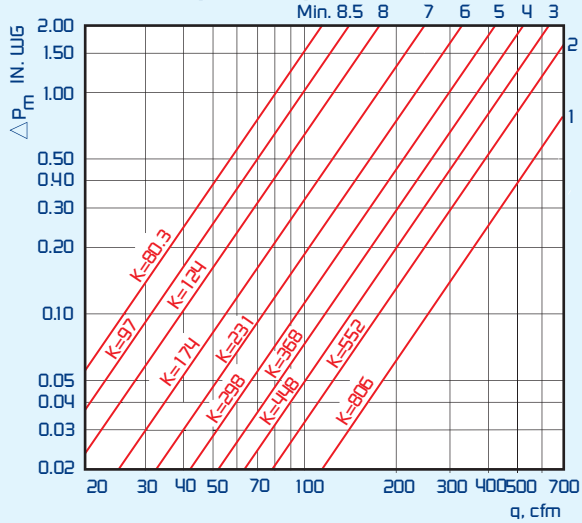

## 8" Damper Adjustment Chart

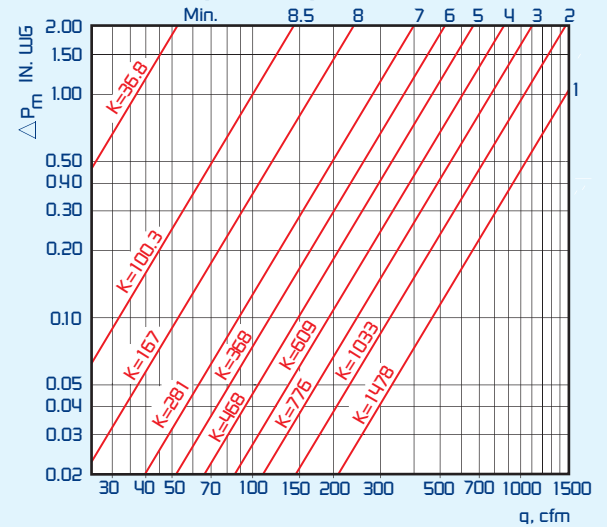

## 10" Damper Adjustment Chart

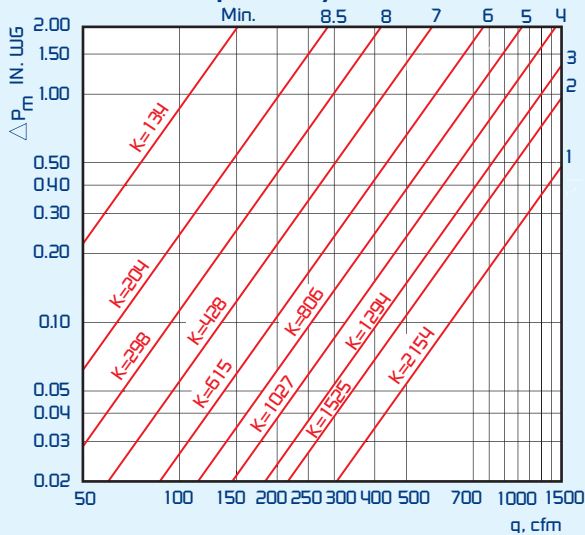

## 12" Damper Adjustment Chart

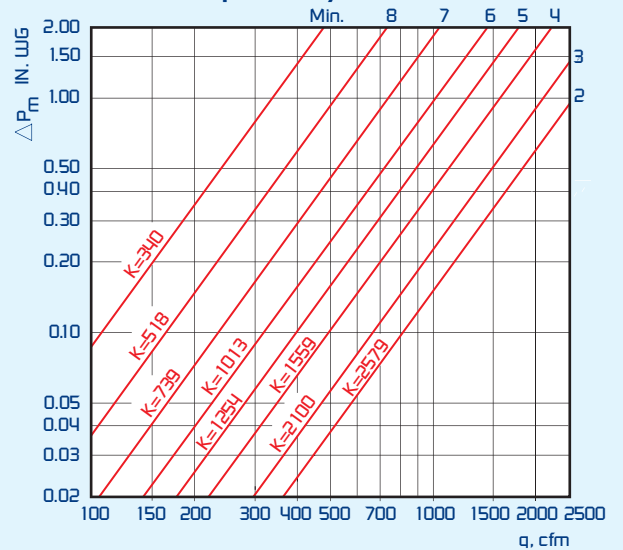

# IRIS-M CONTROL EXAMPLES

## IRIS-M WITH SWITCH CONTROL

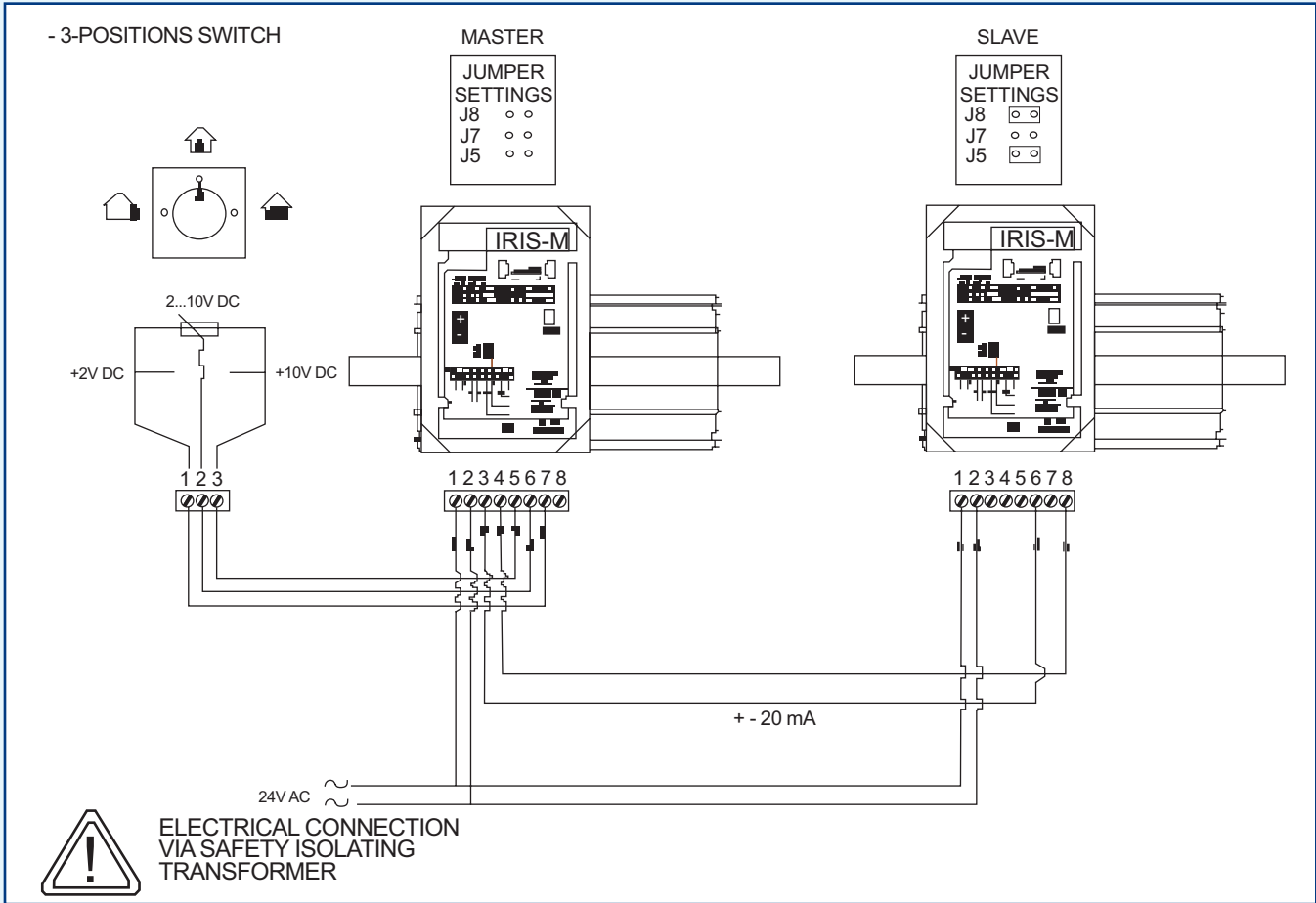

## IRIS-M WITH PROPORTIONAL CONTROL

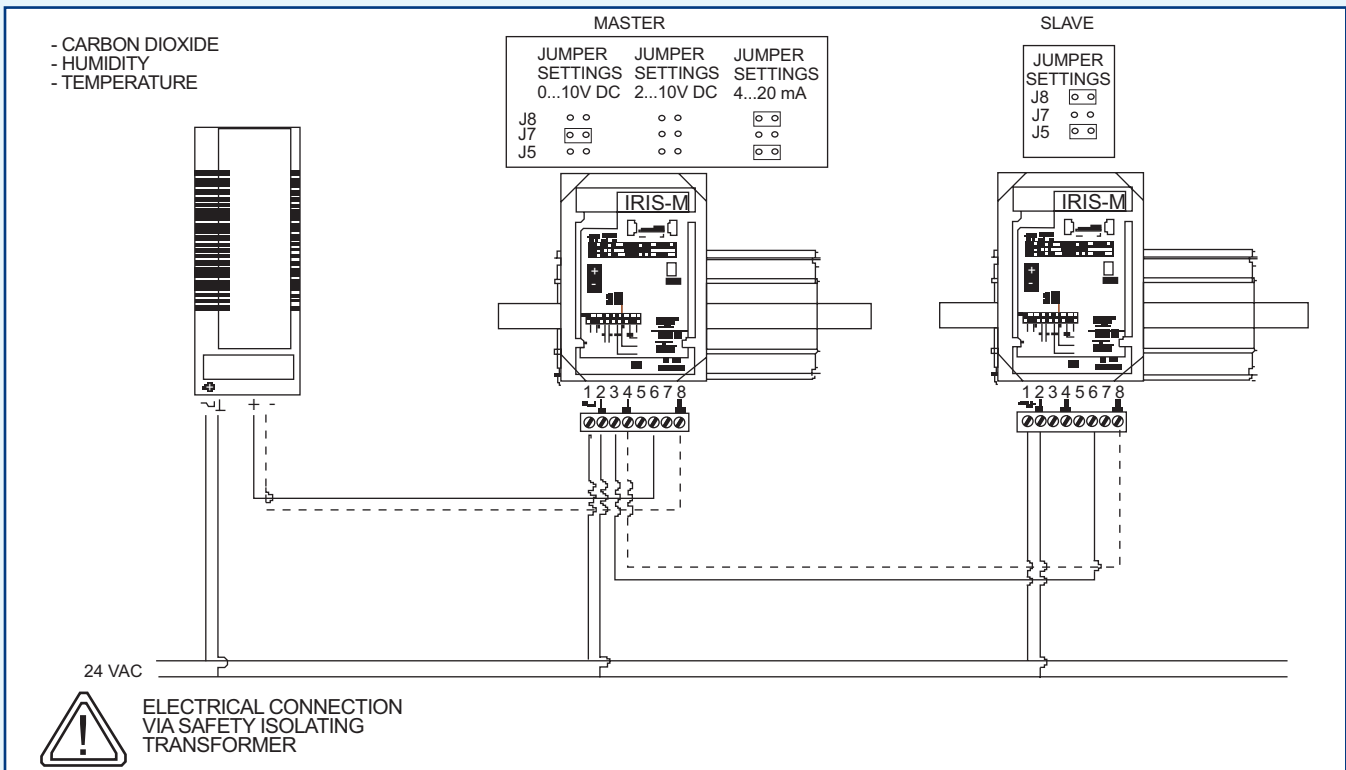

# GUIDE SPECIFICATIONS

## IRIS DAMPER

### 1.0 GENERAL

- A. Iris dampers shall be model IRIS, as manufactured by Continental Fan Manufacturing Inc., of Buffalo, NY, and of the size and capacity as indicated on the drawings and damper schedule.

### 2.0 DAMPER CONSTRUCTION

- A. Iris dampers shall be manufactured of hot dipped galvanized 22 gage steel.
- B. Duct connections shall be gasketed and beaded to provide for a sealed duct connection.
- C. Airflow measurement taps shall be provided with airflow adjustment charts located on the damper for convenient airflow measurement and control. Damper shall be capable of controlling airflow to +/- 7% of design airflow with a minimum of one duct diameter straight duct leading into the unit.
- D. Damper position shall be set with the factory supplied spanner wrench, with no zero calibration required. Dampers requiring zero calibration are not acceptable. Casing leakage to the environment shall not exceed 6 cfm.

## IRIS-S STAINLESS STEEL DAMPER

### 1.0 GENERAL

- A. Iris dampers shall be model IRIS-S, as manufactured by Continental Fan Manufacturing Inc., of Buffalo, NY, and of the size and capacity as indicated on the drawings and damper schedule.

### 2.0 DAMPER CONSTRUCTION

- A. Iris dampers shall be manufactured of 316 acid proof stainless steel.
- B. The duct connections shall be gasketed and beaded to provide for a sealed duct connection.
- C. Airflow measurement taps shall be provided with airflow adjustment charts located on the damper for convenient airflow measurement and control.
- D. Damper shall be capable of controlling airflow to +/- 7% of design airflow with a minimum of one duct diameter straight duct leading into the unit. Damper position shall be set with the factory supplied spanner wrench, with no zero calibration required. Dampers requiring zero calibration are not acceptable. Casing leakage to the environment shall not exceed 6 cfm.

## IRIS-M MOTORIZED DAMPER

### 1.0 GENERAL

- A. Iris dampers shall be model IRIS-M, as manufactured by Continental Fan Manufacturing Inc., of Buffalo, NY, and of the size and capacity as indicated on the drawings and damper schedule.

### 2.0 DAMPER CONSTRUCTION

- A. Iris dampers shall be manufactured of hot dipped galvanized 22 gage steel.
- B. Duct connections shall be gasketed and beaded to provide for a sealed duct connection.
- C. Airflow measurement taps shall be provided with airflow adjustment charts located on the damper for convenient airflow measurement and control. Damper shall be capable of controlling airflow to +/- 7% of design airflow with a minimum of one duct diameter straight duct leading into the unit.
- D. Damper position shall be set with the factory supplied 24 VAC electric actuator, with no zero calibration required. Dampers requiring zero calibration are not acceptable. Damper actuator requires 0-10 VDC, 2-10 VDC or 4-20 ma input signal from a control system by others.
- E. Damper actuator shall provide full open capability to facilitate duct cleaning.

## IRIS-M-PS POSITIVE SEAL DAMPER

### 1.0 GENERAL

- A. Iris dampers shall be model IRIS-M-PS, as manufactured by Continental Fan Manufacturing Inc., of Buffalo, NY, and of the size and capacity as indicated on the drawings and damper schedule.

### 2.0 DAMPER CONSTRUCTION

- A. Iris dampers shall be manufactured of hot dipped galvanized 22 gage steel.
- B. Duct connections shall be gasketed and beaded to provide for a sealed duct connection.
- C. Airflow measurement taps shall be provided with airflow adjustment charts located on the damper for convenient airflow measurement and control. Damper shall be capable of controlling airflow to +/- 7% of design airflow with a minimum of one duct diameter straight duct leading into the unit.
- D. Damper position shall be set with the factory supplied 24 VAC electric actuator, with no zero calibration required. Dampers requiring zero calibration are not acceptable. Damper actuator requires 0-10 VDC, 2-10 VDC or 4-20 ma input signal from a control system by others.
- E. Damper shall be capable of a fully closed position to provide a positive seal.

## Industrial Fan Division

The Industrial Fan Division offers superbly crafted industrial fans and ventilators, expertly supported by a network of independent manufacturers' representatives.



*Panel Fans*

*Centrifugal Fans*

*Flange Fans*

*In-line Fans*

*Roof Ventilators*

*Iris Dampers*

## OEM Fan Division

The OEM Fan Division works closely with original equipment manufacturers to meet their design requirements, offering in-stock fan components, 3D models and custom fan solutions.



*Cabinet Cooling Fans*

*Motorized Axials*

*Motorized Impellers*

*Centrifugal Fans*

*Axial Impellers*

*Centrifugal Impellers*

## Wholesale Products Division

The Wholesale Products Division offers a superior line of in-stock commercial and residential ventilation products, available from wholesalers and distributors across North America.



*Bathroom Fans*

*Air Purification Systems*

*In-Line Duct Fans*

*External Mount Fans*

*Radial Blade Blowers*

*Exhaust Fans*

USA

[www.continentalfan.com](http://www.continentalfan.com)

Continental Fan Manufacturing Inc.  
203 Eggert Road, Buffalo, NY 14215  
Tel: (716) 842 0670 Fax: (716) 842 0611

Canada

[www.aeroflo.com](http://www.aeroflo.com)

Aeroflo Inc.  
12-205 Matheson Blvd. E., Mississauga, ON L4Z 3E3  
Tel: (905) 890 6192 Fax: (905) 890 6193

# IRIS DAMPERS APPLICATION GUIDE

