

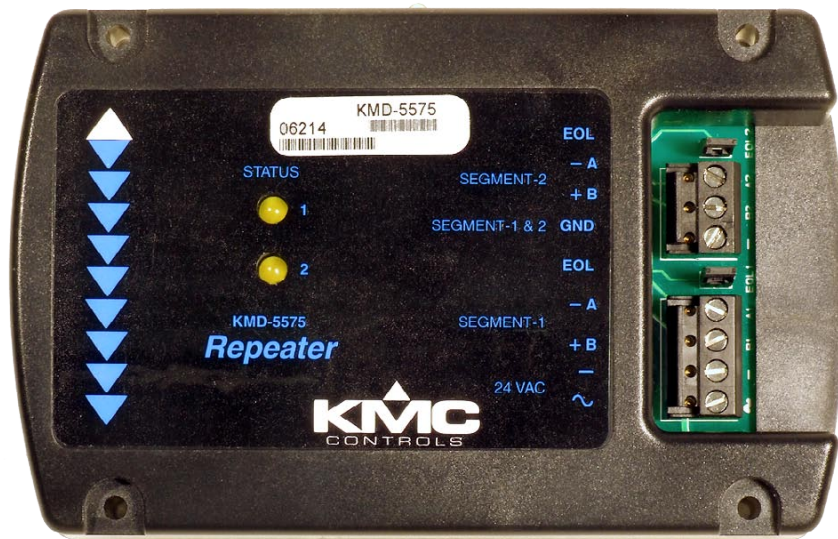

# Installation and Operation Guide



## KMD-5575 Network Repeater-Isolator

### Contents

---

Introduction .....	3
Installation.....	3
Mounting .....	3
Wiring and Terminal Blocks.....	4
Network Connections .....	4
Configuration/EOL.....	7
Power Connection .....	7
Indicators and Operation.....	8
Accessories .....	8
Specifications .....	8

## **Important Notices**

©2008 KMC Controls

The KMC logo is a trademark of KMC Controls, Inc. All rights reserved.

No part of this publication may be reproduced, transmitted, transcribed, stored in a retrieval system, or translated into any language in any form by any means without the written permission of KMC Controls, Inc. Printed in U.S.A.

## **Disclaimer**

The material in this document is provided for information purposes only. The contents and the product(s) described herein are subject to change without notice. KMC Controls, Inc. makes no representations or warranties with respect to this document. In no event shall KMC Controls, Inc. be liable for any damages, direct or incidental, arising out of or related to the use of this document.

**KMC Controls**  
P.O. Box 497  
19476 Industrial Drive  
New Paris, IN 46553  
U.S.A.  
TEL: 574.831.5250  
FAX: 574.831.5252  
E-mail: [info@kmcccontrols.com](mailto:info@kmcccontrols.com)

# Introduction

The KMC KMD-5575 Network Repeater-Isolator extends and reconditions EIA-485 network communications as well as enabling “T” or branch networks. The KMD-5575 is designed to recondition a degraded EIA-485 (formerly RS-485) communication signal on a KMC KMDigital or BACnet subnetwork. Two primary factors that cause communication signal degradation within the digital subnetwork are long subnetwork wiring lengths and the number of digital controllers connected to the subnetwork.

A KMD-5575 is required after every 31 consecutive controllers on KMDigital or BACnet subnetworks (e.g., between controllers 31 and 32) or if the cumulative wiring distance exceeds 4,000 feet. (For smoke control applications, the maximum total length of the EIA-485 network cable, including all repeaters, is 4,000 feet.)

In addition, the KMD-5575 is required for “T” or branch network wiring configurations (see Illustration 4 ).

Illustration 1 shows the major module components and their connections.

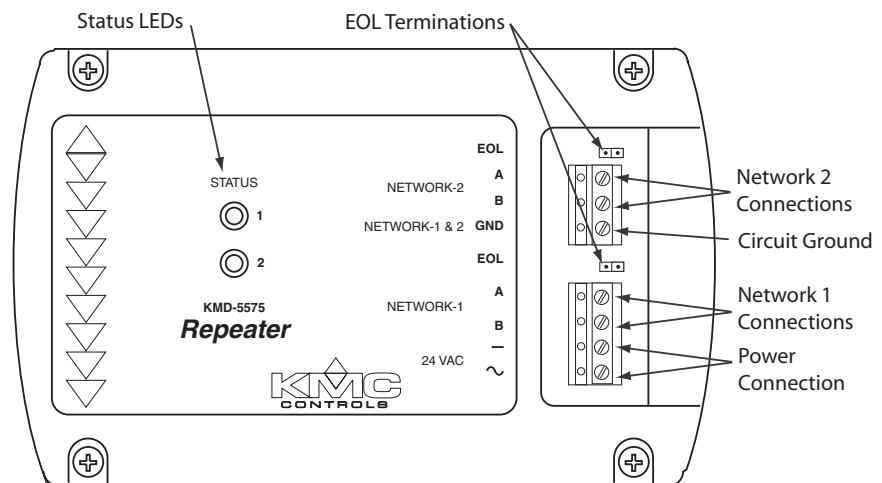

Illustration 1 – Components

# Installation

## Mounting

Fasten the KMC KMD-5575 securely to a flat surface inside a metal enclosure using #6 hardware in the four mounting holes on the top and bottom (see Illustration 2). For HVAC applications, KMC Controls recommends using a UL Listed enclosed energy management equipment panel such as a KMC model HCO-1034, HCO-1035, or HCO-1036. The HCO-1102 enclosure will hold one KMD-5575.

For smoke control applications, the controller must be mounted in a UL Listed Firefighter’s Smoke Control Station enclosure or listed enclosure with minimum dimensions. The minimum enclosure size is 16 x 18 x 6 inches. KMC enclosures HCO-1034, HCO-1035, and HCO-1036 are approved for this application. See Smoke Control Manuals 000-035-08 (BACnet) and/or 000-035-09 (KMDigital).

To maintain RF emission specifications, use either shielded connecting cables or enclose all cables in conduit.

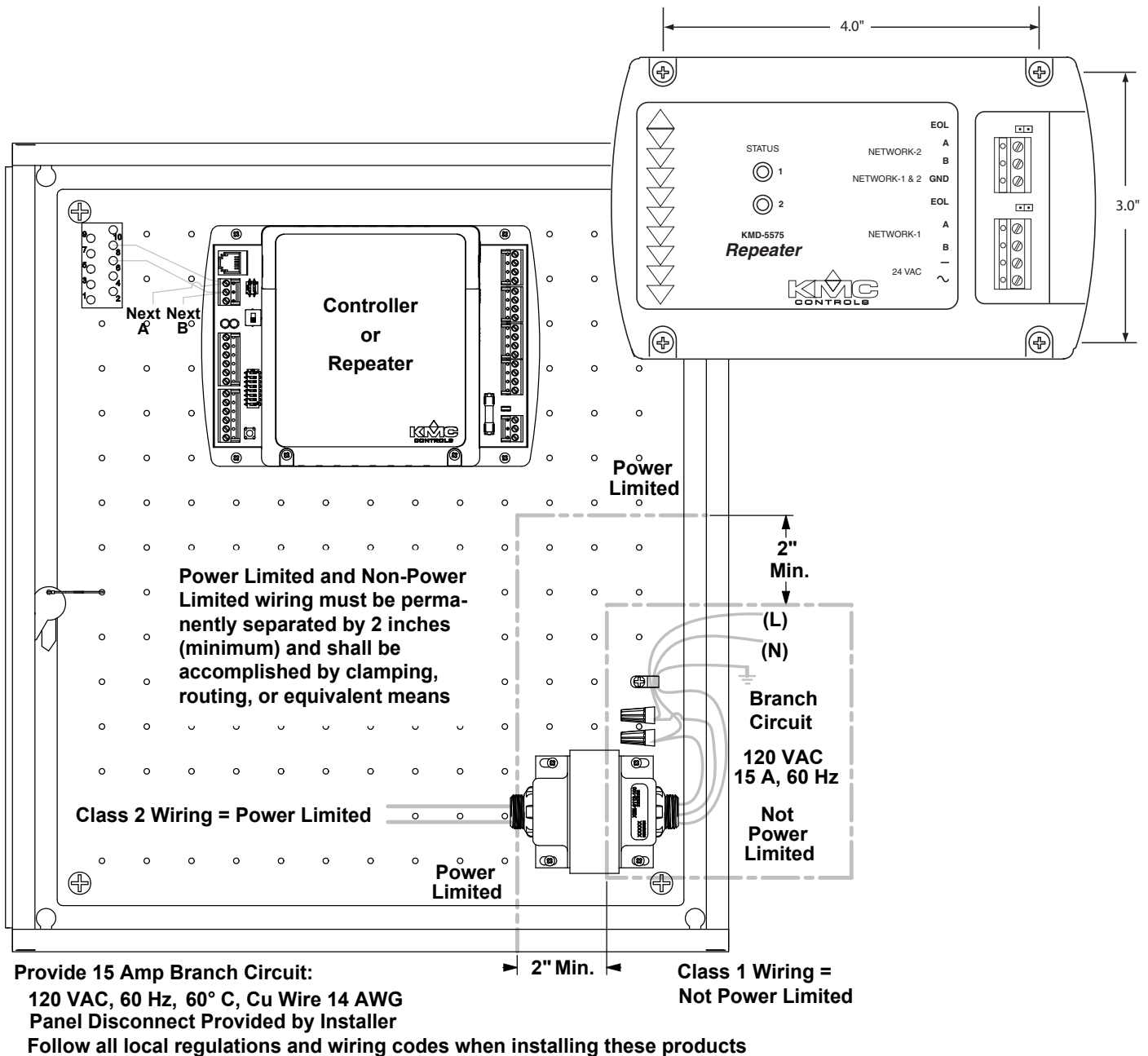

Illustration 2—Mounting and Wire Routing

## Wiring and Terminal Blocks

Terminal blocks are removable for wiring convenience. Wire sizes 14–22 AWG can be clamped into each terminal. No more than two (16 AWG) wires can be joined at a common point.

## Network Connections

The KMD-5575 Network Repeater-Isolator is designed to operate between network segments. Each network is connected to the respective terminals on the module. (See Illustration 1.)

**Connect the shields of the cable together at each device on that segment. Connect the shields to an earth ground only at one end of the segment. Do NOT connect the cable shield to the circuit/segment GND terminal on the KMD-5575.**

Illustration 3 shows a repeater as it might appear connected between two network segments at the End-of-Line (EOL) position. (See the Configuration/EOL section for information about the EOL jumper.)

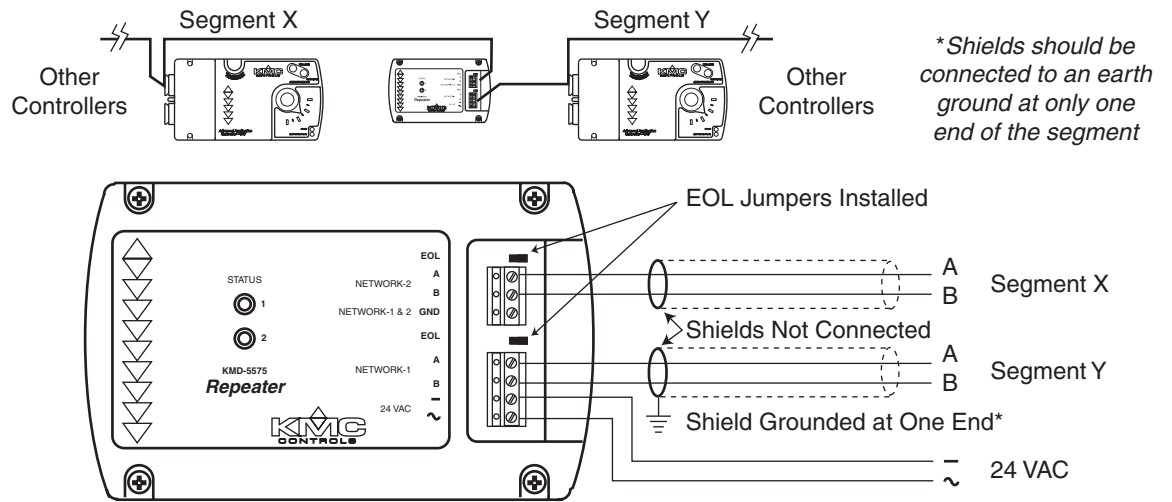

Illustration 3—Repeater at End of Line Between Two Network Segments

Illustration 4 shows a repeater connected in a single “T” or branch network configuration. (One branch is shown coming off a segment.)

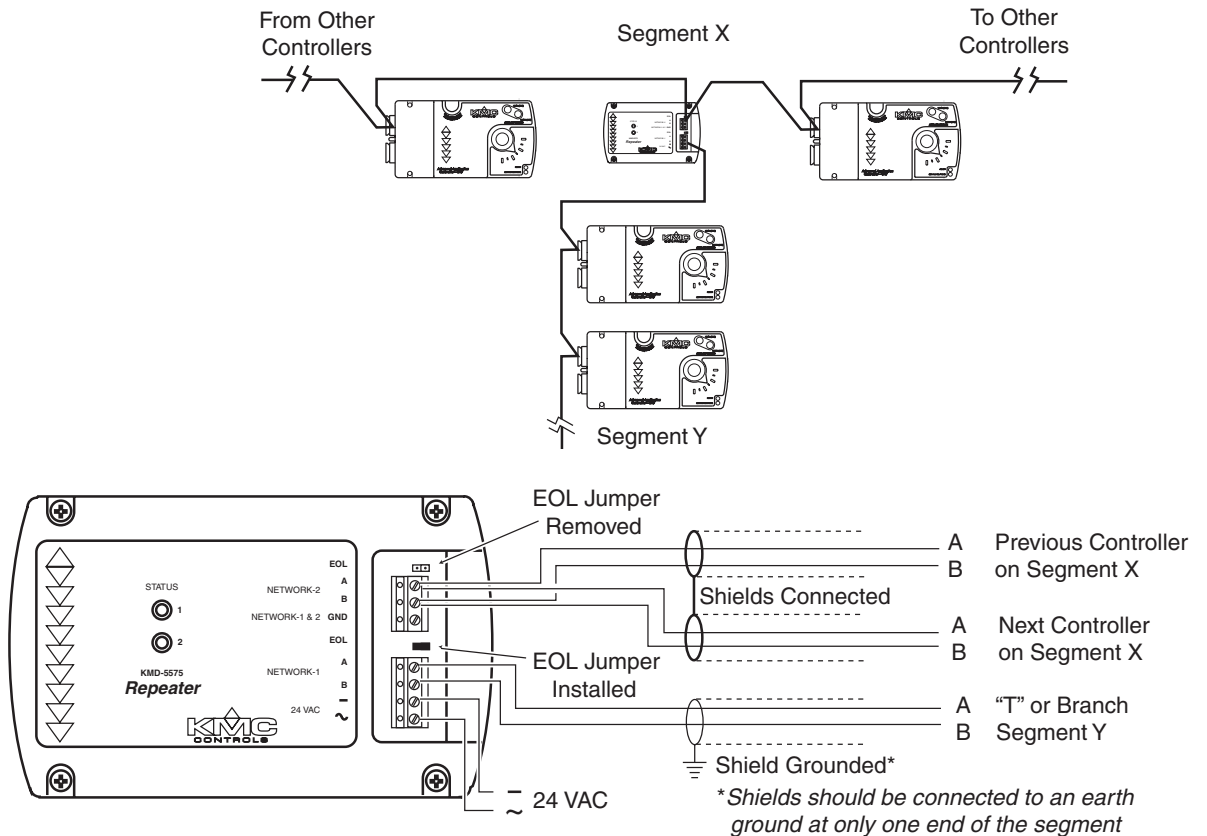

Illustration 4—Repeater in a single “T” or Branch Sublan Configuration

Illustration 5 shows repeaters connected as they might appear in a multiple “T” or branch network configuration. (Three branches are shown coming off a segment.)

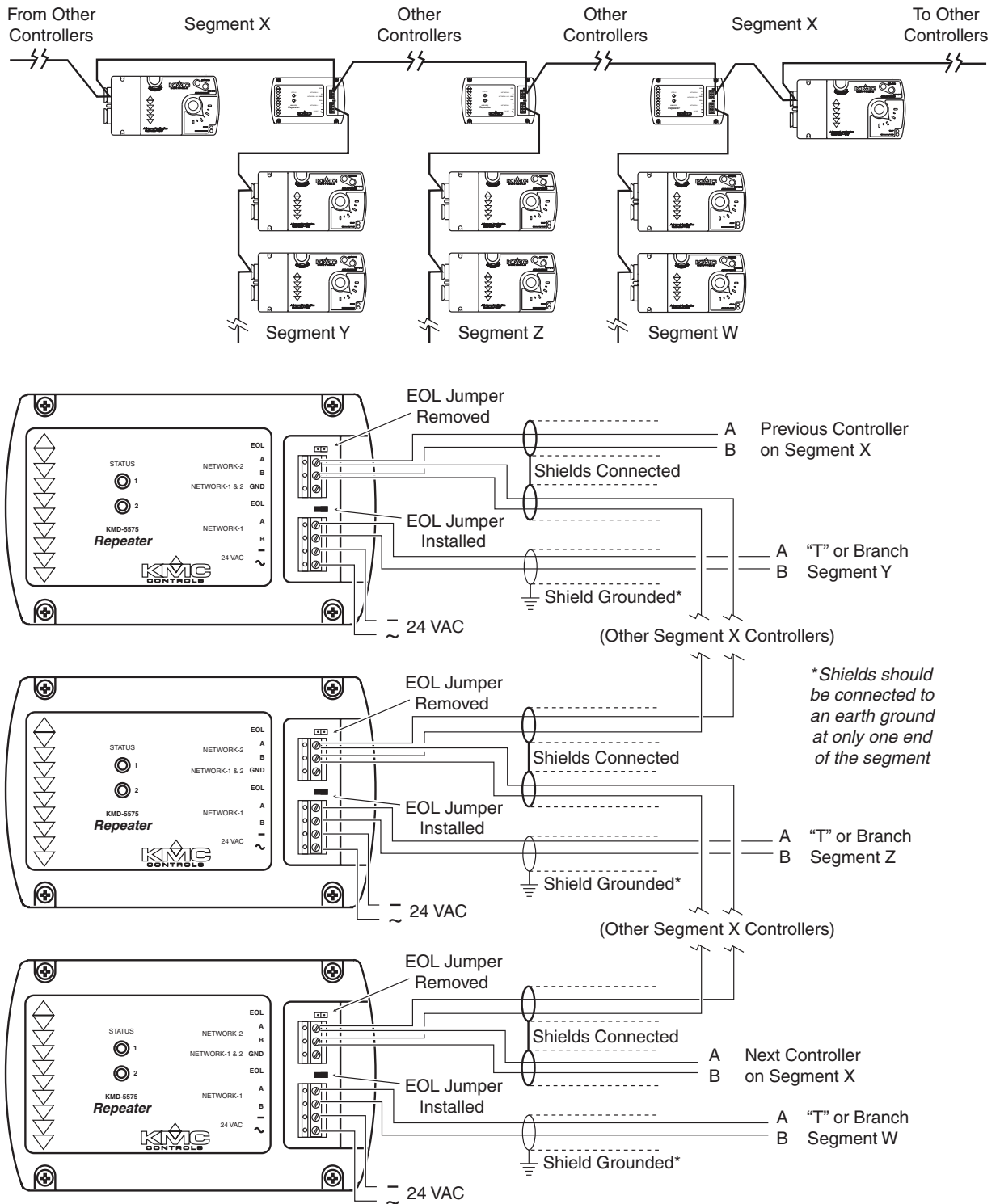

Illustration 5—Repeaters in a multiple “T” or Branch Sublan Configuration

EIA-485 terminals are used for connections to a network of controllers. Refer to this checklist of best practices:

- ◆ **Connect the shields of the cable together at each device. Do not connect the cable shield to the circuit GND terminal on the KMD-5575.**
- ◆ **Connect the shields to a good earth ground at only one end of the segment;** tape back the shield ground at the other end.
- ◆ Use a KMC KMD-5575 repeater after every 31 controllers or if the cable length exceeds 4,000 feet (1,220 meters). Generally, use no more than **four** repeaters per EIA-485 (KMDigital or BACnet) network. (For smoke control applications, the maximum total length of the EIA-485 network cable, including all repeaters, is 4,000 feet.)
- ◆ If the repeater is at an end-of-line position, refer to Illustration 3 and the “Configuration/EOL” section. The end-of-line connection will have only one wire attached to the A and B terminals.
- ◆ For reliable operation, use Belden cable model #82760 or equivalent (18-gauge, twisted, shielded, 50 picofarads or less) for all network terminal block connections.
- ◆ Connect the nodes of the network in a daisy-chain arrangement:
  - Connect the A terminal in parallel with all other A terminals.
  - Connect the B terminal in parallel with all other B terminals.
- ◆ “Star” networks (three or more conductors under the A and B terminals) are **not** recommended. “T” networks can accomplish the same goal.
- ◆ Place a KMC KMD-5567 surge suppressor in the cable run where it exits a building.

For smoke control applications, the maximum total length of the MS/TP network cable, including all repeaters, is 4,000 feet. The MS/TP communications network is supervised in smoke control applications, and the ground fault impedance value for the circuit is 0 ohms. For specific information on smoke control systems, see Smoke Control Manuals 000-035-08 (BACnet) and/or 000-035-09 (KMDigital).

## Configuration/EOL

Prior to operating the KMC KMD-5575 Network Repeater-Isolator Module, you may need to configure the module for an End-of-Line (EOL) termination. See Illustrations 3 through 5.

If the module is connected to the network segment in an end-of-line position (only one set of wires connected to the terminal—refer to “Network Connections” section), place the EOL jumper in the “On” (shorted) position. If the module is not connected in an end-of-line position (two sets of wires connected to the terminal), then leave the jumper in the default “Off” position.

## Power Connection

Before connecting power, make certain all connections and EOL jumper positions are complete and correct. Connect a KMC Controls 24 VAC Class-2 (power limited) transformer of the appropriate size to the two power connections on the lower terminal strip. Connect the ground side of the transformer to the – terminal and the AC phase to the ~ (phase) terminal. See Illustration 3.

For smoke control applications, the KMC XEE-6112-100 transformer is required. See Smoke Control Manuals 000-035-08 (BACnet) and/or 000-035-09 (KMDigital) for smoke control application information.

# Indicators and Operation

---

The module will power up when 24 VAC is applied. No power switches are used with this device. Once connected and powered up, the module operates automatically and requires no user intervention.

Two Status LEDs flash to indicate communications activity on the corresponding network. The **upper LED** monitors Network 1 connected to the **lower bank**, and the **lower LED** monitors Network 2 connected to the **upper bank**.

## Accessories

---

### Connectors and Fuses

902-602-04	Replacement three-pin removable terminal block
031-602-02	Replacement four-pin removable terminal block
HPO-0063	Replacement two-pin jumper

### Enclosures

HCO-1102	Steel control enclosure, 10.1 x 2.4 x 7.1 inches
HCO-1034	Energy management equipment enclosure 16 x 18 x 6"
HCO-1035	Energy management equipment enclosure 20 x 24 x 6"
HCO-1036	Energy management equipment enclosure 24 x 36 x 6"

NOTE: For smoke control applications, the controller must be mounted in a UL Listed FSCS enclosure or listed enclosure with minimum dimensions. See Smoke Control Manuals 000-035-08 (BACnet) and/or 000-035-09 (KMDigital) for smoke control application information.

### Power Transformers

XEE-6111-40	Transformer, 120-to-24 VAC, 40 VA, single-hub
XEE-6112-40	Transformer, 120-to-24 VAC, 40 VA, dual-hub
XEE-6112-100	Transformer, 120-to-24 VAC, 96 VA, dual-hub (required in smoke control applications)

## Specifications

---

<b>Supply Voltage</b>	24 volts AC (-15%, +20%), 60 Hz, 3 VA, Class 2 only
NOTE: All circuits, including supply voltage, are power limited. AC power is non-supervised in smoke control applications.	
<b>Baud Rate</b>	9,600 to 38,400
<b>Connections</b>	Removable screw terminal blocks, wire size 14–22 AWG
<b>Network Wiring</b>	Belden 82760 or equivalent, shielded, twisted, 18 AWG, 5.5 ohms per 1,000 feet and ≤ 51 pF/foot (network connections are supervised in smoke control applications)
<b>Material</b>	Black ABS
<b>Size</b>	5.31 x 3.38 inches (134.9 x 85.8 mm)
<b>Weight</b>	2.5 oz. (71 grams)
<b>Regulatory</b>	UL 916 Energy Management Equipment listed; UL 864 Smoke Control Equipment listed (UUKL)— see Smoke Control Manuals 000-035-08 (BACnet) and/or 000-035-09 (KMDigital) for smoke control application information
<b>Ambient Limits</b>	
Operating	32 to 120° F (0 to 49° C)
Shipping	-40 to 140° F (-40 to 60° C)
Humidity	0 to 95% RH, non-condensing