

Description and Application

The KMC SSS-1000 sensors are designed to sense differential pressure in the inlet section of VAV (Variable Air Volume) terminal units and fan terminal units. They can also be used to sense differential pressure at other locations in the main or branch duct systems. The differential pressure read between the high "H" port and the low "L" port can be used to determine the air flow.

Models offer up to four sensing points and sensing lengths of 3-5/32 to 9-29/32 inches to accommodate box size diameters of 4 to 16 inches.

These sensors are typically used in conjunction with the CSC-1000/2000/3000 series, CSP-4000/5000 series, KMD-7000 series, and BAC-7000 series of VAV controllers for individual zone control in HVAC systems.

With **CSC-3000** series, **CSP-4000/5000** series, **KMD-7000** series, and **BAC-7000** series controllers, use a 3/8" to 1/4" barb union adapter and appropriate polyethylene tubing to the sensor and controller.

For maximum accuracy in the **CSP-5000** series, **KMD-7000** series, and **BAC-7000** series controllers, the 3/8" OD tubing between the sensor and the adapter should be as short as possible, and the 1/4" OD tubing from the adapter to the controller should be 24" long (on both the High and the Low sides).

NOTE: For use with CSC-2000 series, CSC-3000 series, and CSP-4000 series controllers with built-in "differential pressure" sensors, see the formulas in the **SSS-1000 Series Installation Guide**. The CEP-4000, CSP-5000, KMD-7000, and BAC-7000 series operate differently—see their respective installation guides and application guides as well for more information.

RoHS
COMPLIANT



Models

SSS-1002	One sensing point, 3-5/32" (80 mm) length
SSS-1003	Two sensing points, 5-13/32" (137 mm) length
SSS-1004	Three sensing points, 7-21/32" (195 mm) length
SSS-1005	Four sensing points, 9-29/32" (252 mm) length

NOTE: For maximum measurement accuracy, install the longest sensor that will fit in the duct.

Specifications

Material	Light gray ABS/ polycarbonate (UL94-5V)
Mounting	Integral flange with gasket
Connection	1/4" (6 mm) nipple for 3/8" (10 mm) OD polyethylene tubing
Weight	1 oz. (28 grams)
Temperature Limits	
Operating	40 to 120° F (4 to 49° C)
Shipping	-40 to 140° F (-40 to 60° C)
Approvals	RoHS compliant

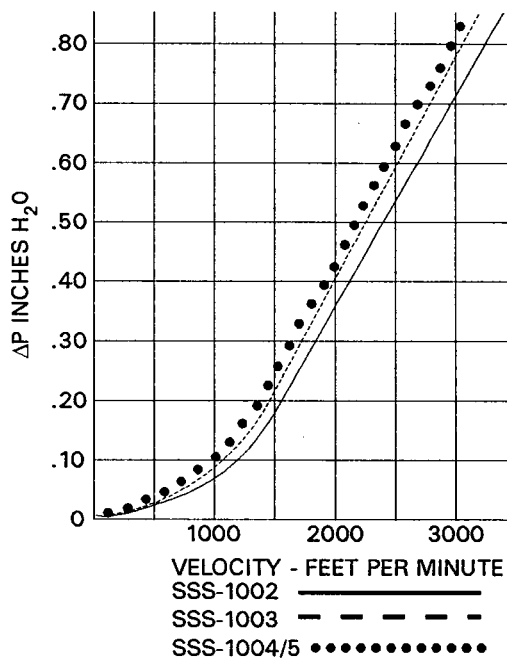

"Feet Per Minute" K Factors	
Sensor Model	K
SSS-1002	3450
SSS-1003	3300
SSS-1004	3200
SSS-1005	3200

Dimensions and Details

All dimension are in inches (mm)

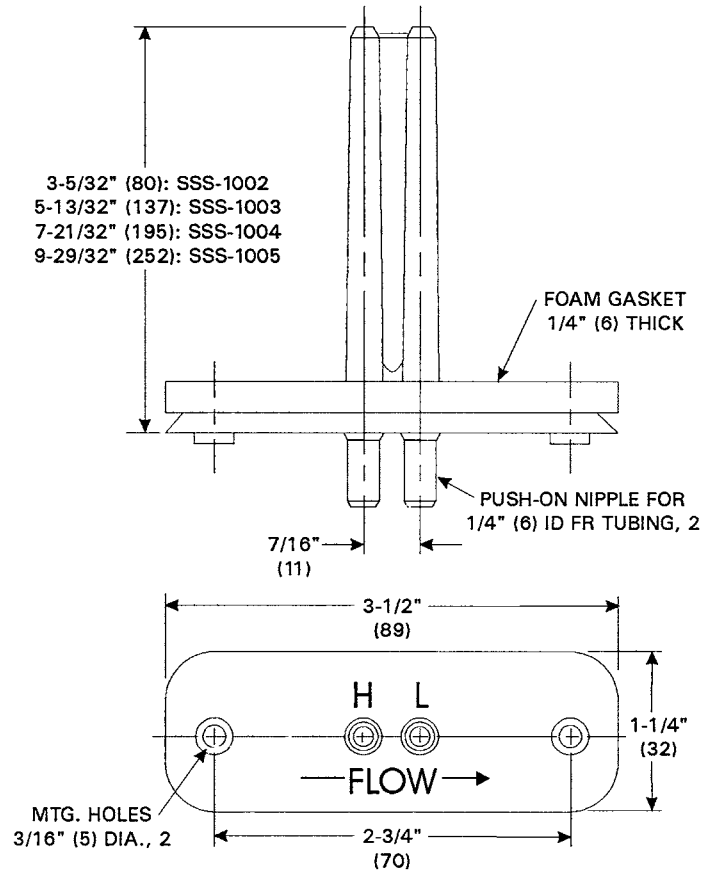

KMC Controls, Inc.

19476 Industrial Drive

New Paris, IN 46553

574.831.5250

www.kmcccontrols.com

info@kmcccontrols.com