

Installation Guide

Required Tools

- digital voltmeter
- small screwdriver
- 2 wrenches

Mounting

The VEP-15 have straight through valve bodies. The VEP-25 have a right angle body design. Valves are sized to the demand of the system and are frequently smaller than supply lines.

1. Clean the lines upstream from the valve. Remove any debris > .06" (.15 mm)
2. Valves may be connected with 3/8" flexible conduit by using a HMO-4530 adaptor (not included).
3. Seal valves with approved valve sealant
4. Install as close as possible to the coil in a vertical position (actuator over the valve).
5. Align system flow with arrow on valve.

CAUTION: Mount valve with the actuator in the upright position, or at most a 45° angle, to prevent condensation collecting in the actuator housing.

6. Allow sufficient side clearance for servicing the valve. Allow a minimum clearance of 1-1/2 " (38mm) between the top of the actuator and the nearest obstruction. This permits removal of the actuator yoke and replacement of the bonnet assembly.

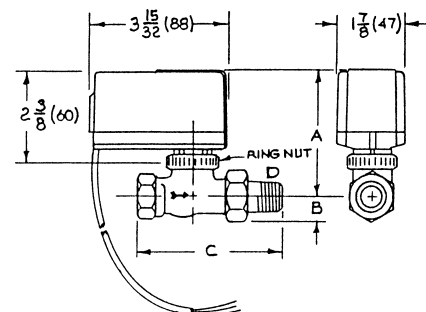

VEP-15 SERIES

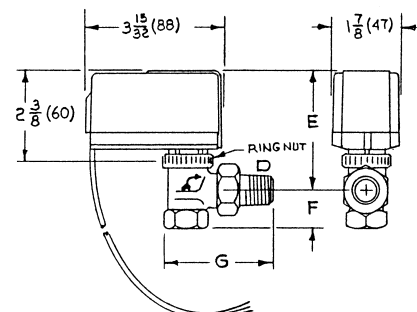

VEP-25 SERIES

Wiring

Wire per diagram for your actuator type.

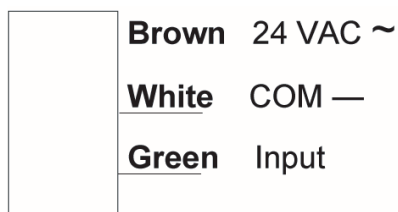

MEP-3011; 2-10 V, Closed - Open
MEP-3016; 10-2 V, Closed - Open

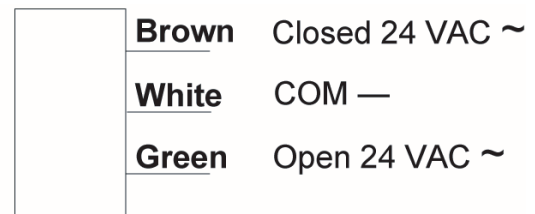

MEP-3010

Maintenance

No routine maintenance is required. Each component is designed for dependable, long term reliability and performance. Careful installation will ensure performance. Limit field repairs to replacement of the complete bonnet assembly or valve disc.

KMC Controls

P.O. Box 497

19476 Industrial Drive

New Paris, IN 46553

U.S.A.

TEL: 574.831.5250

FAX: 574.831.5252

E-mail: info@kmccontrols.com