

©2014 ecobee

477 Richmond St West | 2nd Floor,
Toronto | Ontario | M5V 3E7 | Canada
Toll free 1.877.932.6233
www.ecobee.com

EB-EMSSI-01-rev3





ecobee

EMS Si
Manual

CONTENTS

GETTING STARTED	1
Welcome	1
Technical Support	1
Before You Begin	2
HVAC System Compatibility	3
Approvals	4
FCC Compliance Statement	4
Specifications	5
Wiring Requirements	6
INSTALLING THE EMS Si	7
Step 1. Power Off HVAC Equipment	7
Step 2. Remove Existing Thermostat	7
Step 3. Install the EMS Si	7
Step 4. Connect the Wiring	9
Step 5. Power On HVAC Equipment	20
NAVIGATING THE MENUS	20
Using the Navigation Buttons	20
CONFIGURING THE HVAC SETTINGS	22
Equipment	22
Thresholds	25
Test Equipment	29
Reset HVAC Equipment Settings	29
Performing a Hardware Reset	29
Rebooting the EMS Si	30
Configuring Reminders and Alerts	31

Alerts	32
AUTOMATION	34
Setting Up the Sensor Inputs	34
CONNECTING TO THE INTERNET	40
Setting Up WiFi	41
Configuring a Web Portal Account	42
USING YOUR EMS Si	44
System Mode	45
Fan	45
Weather Forecast	47
Cleaning	47
CONFIGURING YOUR EMS Si	48
Configuring Personal Preferences	48
Utility CPP Setting	54
WiFi	55
Creating Your Weekly Schedule	56
Using the Weekly Schedule Editor	57
Scheduling a Calendar Event	58
3-YEAR LIMITED WARRANTY	61
END-USER SOFTWARE LICENSE AGREEMENT	62

GETTING STARTED

Welcome

The ecobee Energy Management System Si (EMS Si) is the newest technology designed for the commercial market. It is ideal in applications where a simple programmable thermostat does not provide adequate controls and functionality and a full-scale building automation system is too complex and cost prohibitive. The ecobee EMS Si is user-friendly, reduces a building's operating costs, and delivers increased energy conservation.

From their EMS Web Portal, users can remotely monitor, identify, analyze and troubleshoot performance issues; manage the temperature and operational settings from a central location; and take action without having to send a technician on-site.

The ecobee EMS Si can maximize any building's efficiency, reduce energy consumption and deliver significant cost savings.

Technical Support

Our technical support team is available to answer your questions at **1.877.932.6233**, or via email at **support@ecobee.com**.

Before You Begin

This product is intended to be installed by trained service professionals.

This manual explains the procedures for installing the ecobee EMS Si. Please read it carefully before beginning the installation.

The EMS Si is designed to be mounted on the wall in a convenient location.

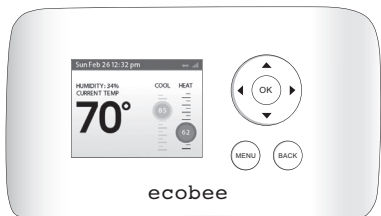

Caution: Disconnect electric power to the HVAC system before installing this product. Failure to do so could result in electric shock and/or equipment damage.

All wiring must conform to your local electrical code.

Mercury Notice: This product does not contain mercury. If you are replacing a product that does contain mercury, contact your local waste-management authority for disposal instructions. Do not discard the old product in the regular trash.

HVAC System Compatibility

The EMS Si is designed to operate with low-voltage heating and cooling systems. It is not designed for use with line-voltage or millivolt heating and cooling systems.

The EMS Si supports:

- Up to 2 heat and 2 cool stages on a conventional system.
- Up to 3 heat and 2 cool stages on a heat pump system.

The ecobee EMS Si supports the following equipment:

Equipment	Supported?
Gas/Oil/Electric heating (up to two stages)	Yes
Heat pump with auxiliary heat (up to three stages)	Yes
Geothermal Heat Pump	Yes
Dual fuel systems	Yes
Standard electric cooling (up to two stages)	Yes
Boilers	Yes
2 remote sensor inputs (dry contact and/or 10K resistive temperature only)	Yes

Approvals

This product was designed and built in accordance to RoHS directive 2002/95/EC and contains no hazardous substances as defined by this directive.

FCC Compliance Statement

This equipment has been tested and found to comply with the limits for Class B digital devices, pursuant to Part 15 of the FCC Rules. These limits are designed to provide reasonable protection against harmful interference in a residential installation. This equipment generates, uses, and can radiate radio frequency energy and, if not installed and used in accordance with the instruction manual, may cause harmful interference to radio communications. However, there is no guarantee that interference will not occur in a particular installation. If this equipment does cause harmful interference to radio or television reception, which can be determined by turning the equipment off and on, the user is encouraged to try to correct the interference by one or more of the following measures:

- Reorient or relocate the receiving antenna.
- Increase the separation between the equipment and receiver.
- Connect the equipment to an outlet on a different circuit from the receiver.
- Consult the dealer or an experienced radio/TV contractor for help.

To satisfy FCC/IC RF exposure safety requirements, a separation distance of 8 inches (20 cm) or more should be maintained between this device and persons. To ensure compliance, operation at closer than this distance is not allowed.

Warning: Changes or modifications not expressly approved by ecobee Inc. could void the user's authority to operate the equipment.

Specifications

Temperature ranges

Heat:	45 to 79 °F (7 to 26 °C)
Cool:	45 to 92 °F (14 to 33 °C)
Display:	40 to 100 °F (5 to 37 °C)
Sensitivity:	+/- 1 °F (0.5 °C)
Operating:	32 to 130 °F (0 to 55 °C)

Humidity Range

Display:	20 to 90% R.H.
Sensitivity:	+/- 5% R.H.
Operating:	5 to 95% R.H (non-condensing)

Dimensions

Thermostat: 5.5"W x 3.25"H x 1"D
(139.5mm H x 82.5mm W x 25mm D)

Power

24 VAC (3VA maximum)

Wiring Requirements

The following table shows the maximum wire lengths allowed:

Thermostat to HVAC Equipment

18 AWG	20 AWG	22 AWG
128 ft/380 m	80 ft/240 m	50 ft/150 m

Terminal Description and Electrical Ratings

Terminal	Description	Voltage	Current Max
N/C	Unused	N/A	N/A
Y	1st stage compressor	24VAC	2A
W (O/B)	1st stage heating or reversing valve changeover	24VAC	2A
G	Fan	24VAC	2A
RC	Cool transformer *	24VAC	2A
RH	Heat transformer *	24VAC	2A
C	Common	24VAC	2A
Y2	2nd stage compressor	24VAC	2A
W2 (AUX)	2nd stage heating or 1st stage auxiliary heat	24VAC	2A
R1+	Input 1+	Temperature/dry contact only	
R1-	Input 1-	Temperature/dry contact only	
R2+	Input 2+	Temperature/dry contact only	
R2-	Input 2-	Temperature/dry contact only	

** Factory jumper installed between RC and RH. Remove jumper for 2-transformer applications. See wiring diagrams for additional information.*

INSTALLING THE EMS Si

There are 5 steps to install the ecobee EMS Si:

- Step 1. Power Off HVAC Equipment
- Step 2. Remove Existing Thermostat
- Step 3. Install the EMS Si
- Step 4. Connect the Wiring
- Step 5. Power On HVAC Equipment

Step 1. Power Off HVAC Equipment

Before disconnecting the existing thermostat, or installing the EMS Si, disconnect the power to the heating and air conditioning equipment.

Step 2. Remove Existing Thermostat

Disconnect the wires to the existing thermostat and remove it from the wall (if you are installing the EMS Si in the same location).

Step 3. Install the EMS Si

The ideal location for the thermostat is approximately 5 ft (1.5 m) above floor level in the main living area.

Do not install the thermostat:

- Close to sources of heat such as incandescent lights
- Near supply heating/cooling sources
- In direct sunlight
- On exterior, non-insulated or poorly insulated walls
- In the kitchen or other areas of potentially high heat and/or humidity
- In an area that could restrict air flow

To install the thermostat:

1. Gently separate the backplate from the thermostat.
2. Place the thermostat backplate on the wall. Make sure that any existing wires can be inserted through the opening for the wiring.
3. Using the backplate as a template, mark the location of the mounting holes on the wall as shown below.

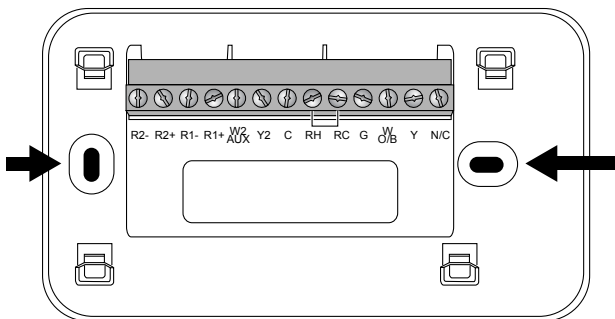

The solid color indicates mounting holes

4. Move the backplate out of the way and make holes where indicated in step 3. The mounting holes can accommodate a #6 pan-head screw. It is recommended to use the included fasteners to ensure proper fitting of the front housing.
5. Use the included drywall plugs (or other suitable anchors) to ensure the thermostat can be mounted securely to the wall.
6. Fasten the backplate to the wall using the screws provided (or other suitable screws).

Step 4. Connect the Wiring

You need to use low-voltage cable to connect the thermostat to the HVAC equipment. Check the wiring diagrams on pages 10 to 19 for the number of wires required.

Note: There is a factory installed jumper between R/H and R/C. Ensure any unused wires do not have exposed bare copper conductors.

To connect the thermostat to the equipment:

1. Connect the wires as shown in the wiring diagrams.
2. Attach the EMS Si to the backplate. Ensure that the pins on the thermostat align with the terminal block on the backplate.

Wiring Diagrams

The following diagrams show how to connect the thermostat terminals to various HVAC equipment.

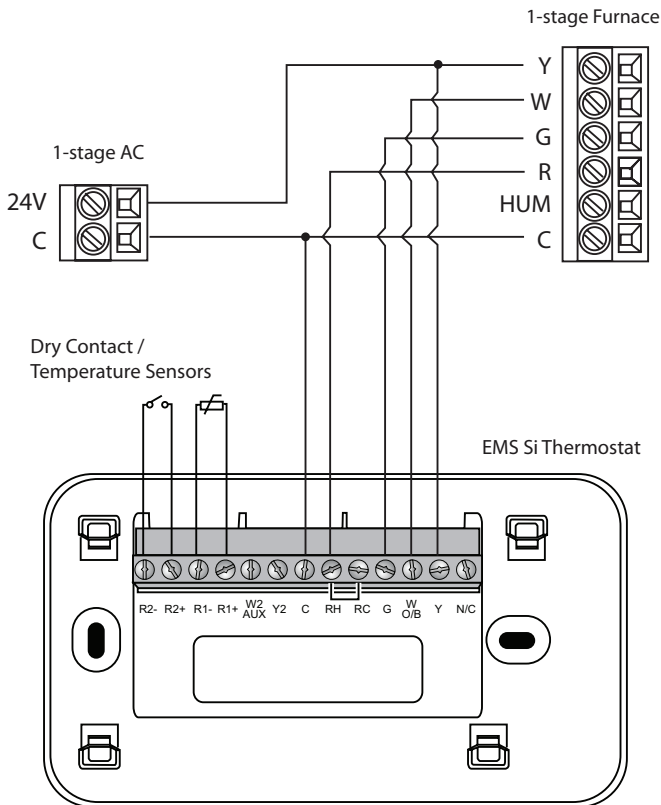

Single stage heat/cool

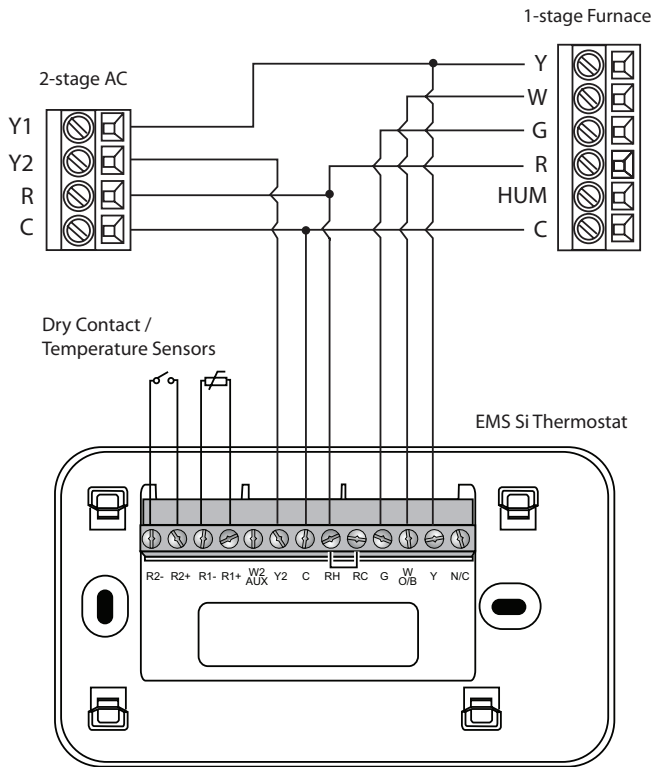

Single stage heat, dual stage cool

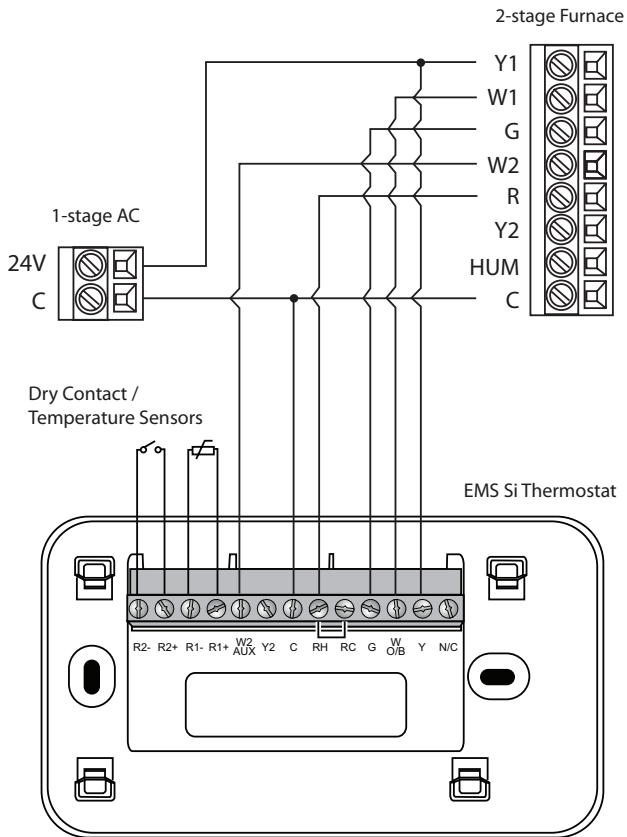

Dual stage heat, single stage cool

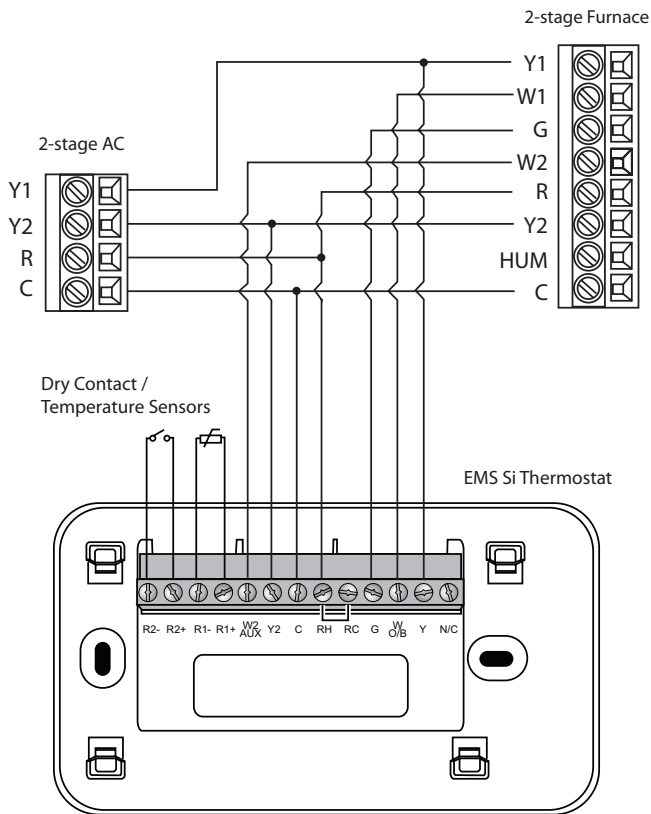

Dual stage heat, dual stage cool

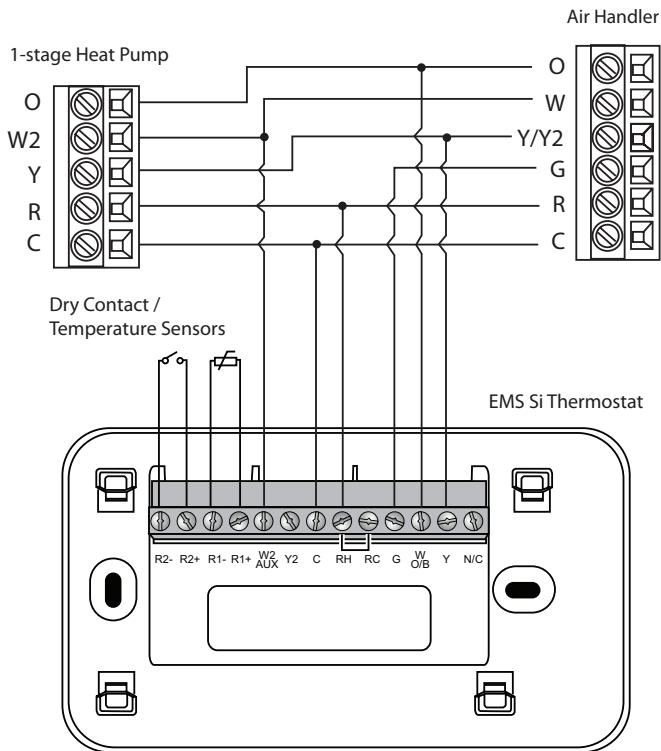

Single stage heat pump with auxiliary heat

2-stage Heat Pump

Air Handler

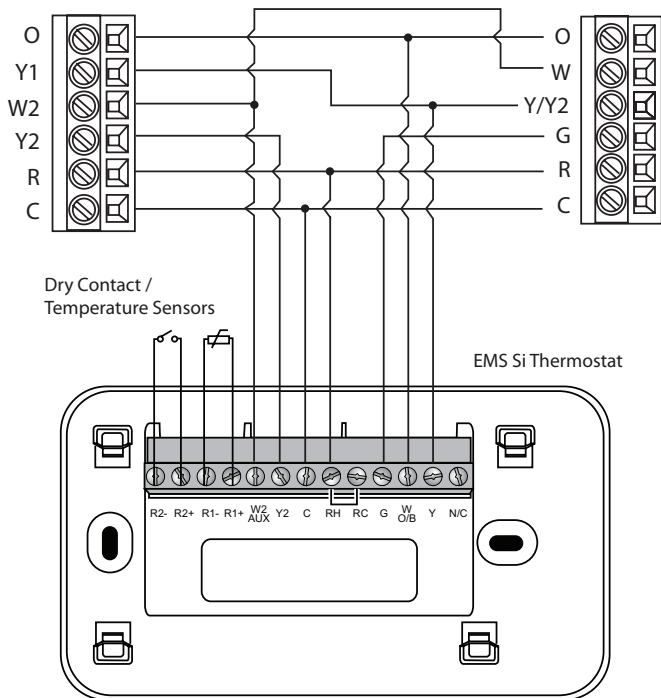

Dual stage heat pump with auxiliary heat

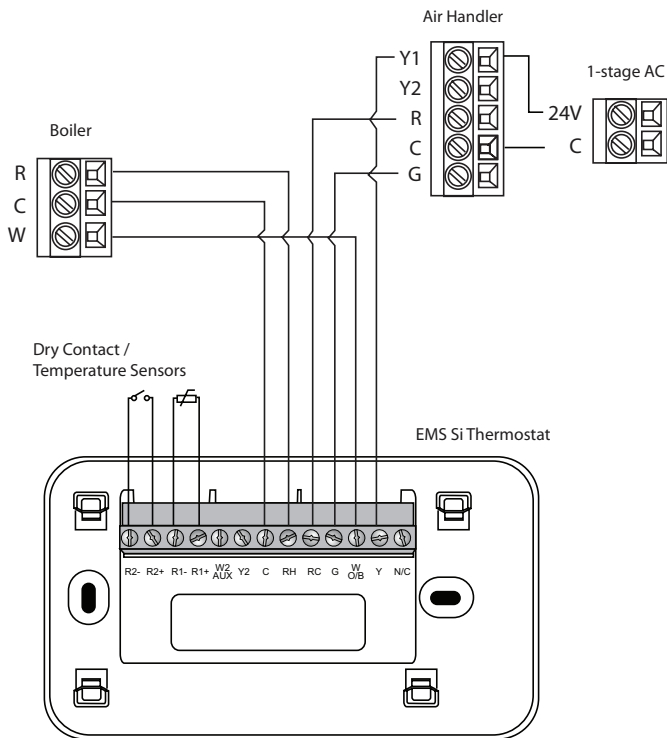

** Remove RH/RC factory jumper*

C terminal to be connected to heating transformer common

Boiler with air handler and single-stage cool

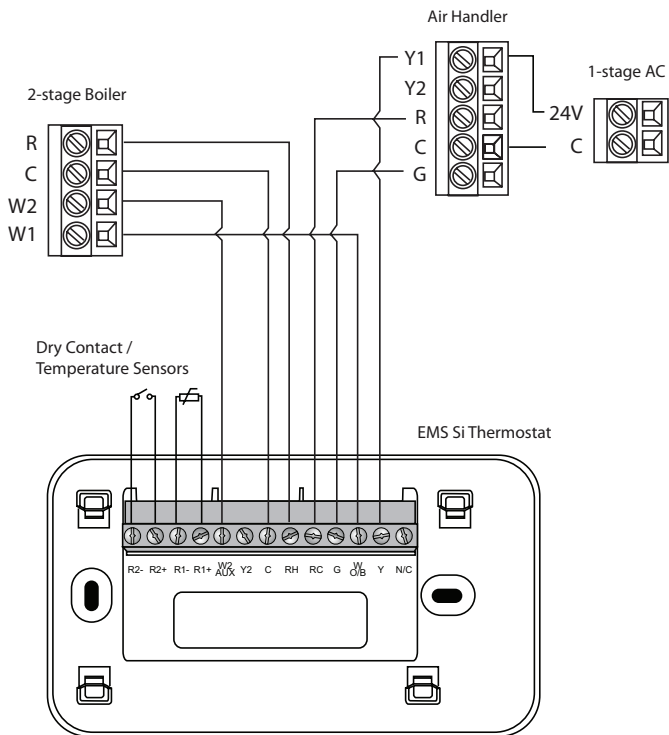

** Remove RH/RC factory jumper*

C terminal to be connected to heating transformer common

Dual stage boiler with air handler and single stage cool

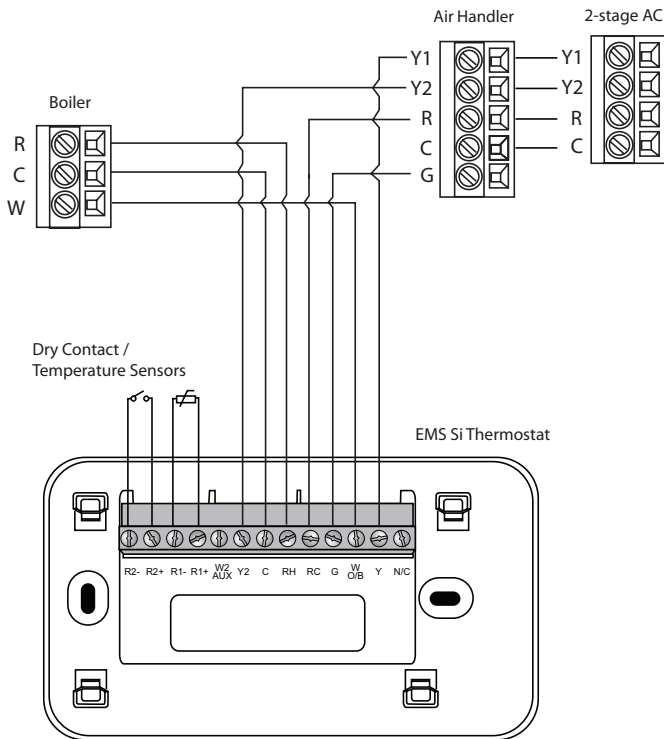

** Remove RH/RC factory jumper*

C terminal to be connected to heating transformer common

Single stage boiler with air handler, dual stage cool

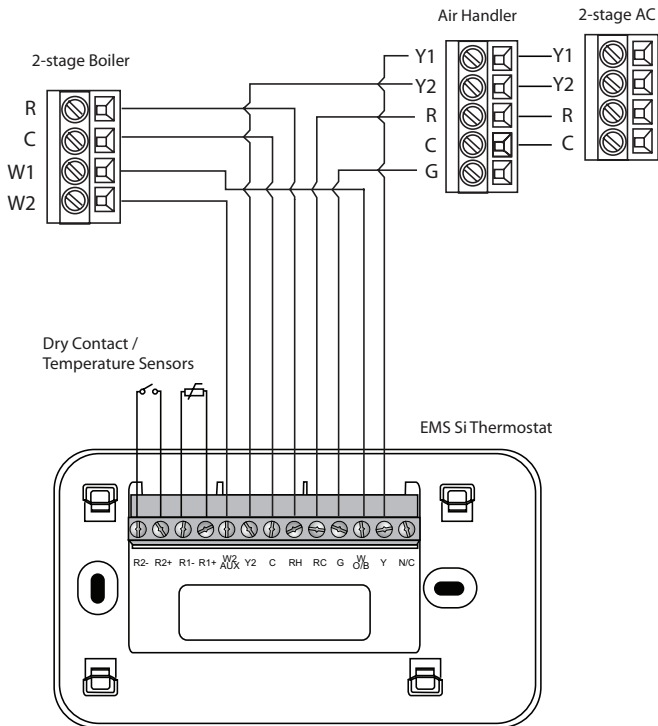

** Remove RH/RC factory jumper*

C terminal to be connected to heating transformer common

Dual stage boiler with air handler, dual stage cool

Step 5. Power On HVAC Equipment

After you've completed the wiring, you can apply power to the heating and air conditioning equipment. The EMS Si receives power from the equipment and will automatically power on.

NAVIGATING THE MENUS

The EMS Si has an easy-to-read color screen that displays all the information you need to configure the thermostat. Use the navigation buttons on the right to quickly change the temperature, access features, and configure settings.

Using the Navigation Buttons

The navigation buttons located on the right of the EMS Si let you select options and control the EMS Si.



- **▲ (up)** On the Home screen, press ▲ to increase the temperature set point by 1°F (0.5°C). For menus, press ▲ to move up.
- **▼ (down)** On the Home screen, press ▼ to decrease the temperature set point by 1°F (0.5°C). For menus, press ▼ to move down.
- **◀ (left)** On the Home screen, if Auto mode is enabled, press ◀ to switch between heat and cool set points. For menus, press ◀ to go back to the previous screen.

- **▶ (right)** On the Home screen, if Auto mode is enabled, press ▶ to switch between heat and cool set points. For menus, press ▶ to choose the currently highlighted option.
- **OK** On a menu screen, press **OK** to choose the currently highlighted option. If a configuration option is selected, pressing **OK** will keep its new value and return back to the previous screen.
- **MENU** Pressing **MENU** displays a list of all available options. If a menu is currently displayed, pressing **MENU** will cancel any unsaved changes and return to the Home screen.
- **BACK** On a menu screen, press **BACK** to go back to the previous screen.



On-Screen Keyboard

If you need to type in any information, an on-screen keyboard will appear. To enter a letter or number, move to the character by pressing the arrow keys and then press **OK** to select it.

Select **Caps** to enter capital letters; select **&@#** to enter commonly used symbols. If you make a mistake, press **X** to delete the text .

To keep your changes, select **Save** . To cancel your changes, press **BACK**.

CONFIGURING THE HVAC SETTINGS

The first step after installing the EMS Si is to configure the settings for the various devices (such as a furnace or air conditioner) that are being connected.

To configure the equipment settings:

From the Home screen, press **MENU**.

Select **Settings** ► **Installation Settings**.

Select **Equipment**.

Configure the devices connected to the EMS Si.

Equipment

The Equipment settings let you configure the devices connected to the thermostat.

Heat Pump

This section lets you configure a heat pump with up to 2 heat/2 cool stages plus an auxiliary heat source.

- **Geothermal heat pump** Select Yes if you are using a geothermal heat pump. This helps the thermostat determine optimum performance and default settings. If you select No, the system will optimize the settings for an air-to-air heat pump.
- **OB energize on cool** If you choose Yes, the reversing valve output (O/B terminal) will activate when there is a call for cooling. If you select No, the relay will activate when there is call for heat.
- **Min Cycle Off Time** Configures the minimum compressor off time between cycles (240 to 900 seconds).
- **Min Outdoor Temp** Disables the compressor when the outside air temperature reaches the configured minimum setting. This performs two functions. It prevents the compressor

from running when the outdoor temperature is too low, thus resulting in damage to the compressor. You can also set this value to determine when you want the auxiliary heat (if installed) to engage to help meet the set temperature. The temperature range is adjustable from 0 to 65 °F (-17.8 to 18.3 °C) or can be completely disabled. Note: You need an internet connection for this feature to operate properly.

- **Allow HP with Aux Heat** If you select Yes and there is a source of auxiliary heat, it will turn on in addition to the heat pump. The heat pump will be energized for the first 30 minutes. If, after 30 minutes, the set point has not been met, the auxiliary heat will be energized to assist the heat pump in meeting the load.

If you select No, the heat pump will be energized for up to 2 hours. If after 2 hours the set point has not been met, the thermostat will shutdown the heat pump and energize the auxiliary heat to meet the set point. This option should also be used for installation where the heat pump evaporator coil is downstream from the source of auxiliary heat.

This setting is only available the Comp to Aux Temp Delta and Comp to Aux Runtime settings are both set to Auto (default)

Furnace

Allows you to enable and configure up to a 2-stage conventional heat source. If you have selected a heat pump as your primary source, this feature allows you to configure the 1st stage of auxiliary heat connected to the system.

- **Furnace Type** Allows you to configure the type of furnace. This helps the thermostat optimize its algorithms based on the type of fuel and typical characteristics of the chosen system. Choose the option that best represents the type of heating system installed.
- **Heat Fan Control** Configures the furnace fan to be controlled by the EMS Si or the HVAC system during heat cycles. Normally the HVAC system controls the fan during heat cycles.

Air Conditioner

Configures up to 2 stages of air conditioning. If you require a second stage, you must enable the Y2 relay.

Thresholds

This section configures the temperature and time thresholds associated with the heating and cooling equipment.

You must configure the Equipment settings (page 25) before setting the thresholds. Only the applicable threshold settings will be displayed (i.e. if no air conditioner is configured, you will not see the options related to air conditioners).

Allow Auto Heat/Cool

Enabling this option allows the user to select auto change-over as a system mode.

Heat/Cool Min Delta

The minimum difference between the heat mode set temperature and the cool mode set temperature when the system mode is in auto change-over. The delta is adjustable from 2 to 10 °F (1.1 to 5.5 °C). The default value is 5 °F (2.8 °C).

Compressor Settings

Min Cycle Off Time Configures the compressor off time between cycles. This ensures the compressor does not short cycle (which could affect the operating life of the system). This time is adjustable from 240–900 seconds.

Min Outdoor Temp Configures the minimum outside air temperature at which the compressor will be disabled. This performs two functions. It prevents the compressor from running when the outdoor temperature is too low, thus resulting in damage to the compressor. You can also set this value to

To configure threshold settings:

From the Home screen, press **MENU**.

Select **Settings** ► **Installation Settings**.

Select **Thresholds**.

Configure the temperature threshold settings.

determine when you want the auxiliary heat (if installed) to engage to help meet the set temperature. The temperature range is adjustable from 0 to 65 °F (-17.8 to 18.3 °C) or can be completely disabled. Note: You need an internet connection for this feature to operate properly.

AC Overcool Max When using the AC to dehumidify, the setting configures how many degrees below the current set point the thermostat will run in order to decrease humidity. Options are Disabled (default) or from 0.5 to 5 °F (0.3 to 2.8 °C).

Aux Heat Settings

Max Outdoor Temperature Configures the maximum outdoor temperature threshold. Above this level, the auxiliary heat will not be activated. The temperature is adjustable from 0 to 80 °F (26.5 °C) in increments of 0.5°F (0.3°C). The default value is 70°F (21°C).

Common Heat/Cool Settings

Heat Differential Temp The minimum difference between the current temperature and set temperature before the system calls for heat. A smaller difference means shorter cycle times, whereas a larger difference results in longer cycle times. The temperature range is adjustable from 0 to 3 °F (-17.5 to 26.5 °C) in 0.5°F (0.3°C) increments.

Heat Dissipation Time The amount of time the fan will run after the heat set point has been reached and the call for heat has been turned off. Running the fan for a period of time allows for any heated air left in the ducts to circulate throughout the building. The

time is adjustable from 0 to 900 seconds. The default value is 30 seconds.

Cool Differential Temp The minimum difference between the current temperature and set temperature before the system calls for cool. A smaller difference means shorter cycle times, whereas a larger difference results in longer cycle times. The temperature range is adjustable from 0 to 3 °F (0.3 to 1.7 °C) in 0.5°F (0.3°C) increments.

Cool Dissipation Time The amount of time the fan will run after the cool has been turned off. Running the fan for a period of time allows for any cooled air left in the ducts to circulate throughout the building. The time is adjustable from 0 to 900 seconds. The default value is 30 seconds.

Advanced Settings

These options customize how long each stage will run before the next stage turns on. You may also program when a particular stage is turned on based on the temperature delta between the set temperature and the current temperature.

- **Reverse Staging** If enabled, the thermostat will cycle down from the higher stages so that as it approaches set point it will only be running in stage 1. The HVAC equipment will start in stage 1. As the stage 1 temperature delta is exceeded, the second stage will engage. Once the equipment has brought the current temperature back to within the heat or cool differential setting, stage 2 will disengage and stage 1 will remain running until the set point is met.
- **Stage 2 Temp Delta** The minimum difference

between the current temperature and the set temperature that will activate the auxiliary heat (regardless if the maximum run time of the previous stage was reached). Options are Auto (default) and 1 to 10 °F (0.6 to 5.6 °C).

- **Stage 1 Max Runtime** The maximum amount of time stage 1 will run before engaging the next stage. Options are Auto (default) and 10 to 120 minutes.
- **Comp to Aux Temp Delta** The maximum amount of time this stage will run before engaging the next stage. Options are Auto (default) and 1 to 10 °F (0.6 to 5.6 °C).
- **Comp to Aux Runtime** The minimum difference between the current temperature and the set temperature that will activate this stage (regardless if the maximum run time of the previous stage was reached). Options are Auto (default), Disabled, and 1 to 10 °F (0.6 to 5.6 °C).
- **Cool Min On Time** Sets the minimum equipment run time in cool mode: 1 to 20 min (default is 5 min).
- **Heat Min On Time** Sets the minimum equipment run time in heat mode: 1 to 20 min (default is 5 min).

Temp Correction

Lets you program an offset between the real temperature at thermostat and the displayed temperature. If you find that the temperature where the thermostat is located does not represent the room temperature, change the offset to compensate for the difference. The correct temperature is adjustable from +/- 10°F in 0.5°F (0.3°C) increments.

Installer Code

To prevent accidental modifications to the installation settings, you can enable a 4-digit installer code. This code is pre-programmed to 3262.

Test Equipment

These options let you test the wiring and connections of the devices connected to the thermostat by turning them on or off.

The equipment will turn off when you exit the menu.



Warning: Compressor protection and minimum run-time features are not enforced while in this mode.

Reset HVAC Equipment Settings

You can quickly restore all HVAC equipment settings on the EMS Si back to their factory defaults. Any user setting (not related to the equipment installed) will remain unchanged.

If you need to reset the entire thermostat back to its original factory default settings, including user settings and registration, select **Reset All Settings** instead.

Performing a Hardware Reset

In rare circumstances, static electricity or power surges may interrupt the operation of the thermostat, forcing a hardware reset.

To test the equipment:

From the Home screen, press **MENU**.

Select **Settings** ► **Installation Settings**.

Select **Test Equipment**.

Select **OK**.

Test the equipment connected to the thermostat by turning each component on and off.

To reset the EMS Si:

From the Home screen, press **MENU**.

Select **Settings** ► **Reset**.

Select **HVAC Equipment Settings**.

Select **Yes**.

Rebooting the EMS Si

You can reboot the EMS Si by pulling the thermostat from the backplate. Rebooting will not alter programming or configuration options.

Configuring Reminders and Alerts

To configure Reminders and Alerts

From the Home screen, press **MENU**.

Select **Reminders and Alerts**.

Configure the Reminder and Alert settings as required.

The Reminders and Alerts list displays the reminders and alerts described below.

HVAC Service

The HVAC Service (maintenance) reminder generates an alert telling the property owner that regularly scheduled maintenance is required.

If the property owner has been added to the EMS account, the reminders will be emailed to them and be displayed in the web portal.

You can set the Last Service date, turn the Reminder On or Off, and to set the Frequency of the maintenance interval in months.

Furnace Filter

Generates an alert for cleaning or changing the filter. You can set the Last Filter Change date, turn the Reminder On or Off, and set the Frequency of the maintenance interval.

UV Lamp

Sets the reminder period for cleaning or replacing a UV lamp. You can set the Last Lamp Change date, turn the Reminder On or Off, and set the Frequency of the maintenance interval.

Alerts

The EMS Si can generate alerts if the temperature in the building goes over or under a pre-programmed level. This protects the building from damage due to freezing and/or excessive heat.

This alert, along with optional technician contact information will be displayed on the screen. If the building owner registers the thermostat, the alert will be emailed to them and be displayed in the web portal.

Low Temp Alert Sets the temperature at which the thermostat will generate a Low Temperature Alert. The range can be:

- **Off** – no alert will be generated.
- Set temperature range of 35 to 68 °F (1.5 to 20 °C).

High Temp Alert Sets the temperature at which the thermostat will generate a High Temperature Alert. The range can be:

- **Off** – no alert will be generated.
- Set temperature range of 60 to 104 °F (15.5 to 40 °C).

Display Alerts on Thermostat

Select No if you do not want any of the alerts to be displayed on the EMS Si screen. Alerts will continue to be displayed on the web portal and sent via email.

Enable Heating/Cooling Alerts

Select No to disable alerts for heat/cool error conditions. If disabled, alerts indicating that the system failed to heat or cool will not be appear in the screen, web portal, or emails.

List of Alerts

Below is a complete list of alerts. Depending on your configuration, some of these may not apply.

Furnace Air Filter	Furnace filter needs to be cleaned or changed.
UV Lamp	UV lamp needs to be changed.
Low Temp Alert	Temperature in the building is too low.
High Temp Alert	Temperature in the building is too high.
Heat Not Responding	The system has failed to heat the building.
Cool Not Responding	The system has failed to cool the building.
Maintenance Reminder	HVAC system due for regular maintenance.
Auxiliary Heat Run Time	Auxiliary heat source is running too often.
Auxiliary Outdoor Temperature	Your EMS Si auxiliary heat has been called to run when the outdoor temperature exceeds the programmed set point.

AUTOMATION

The EMS Si can be configured to perform actions based on the status of up to 2 external sensors (dry contact or external temperature resistive).

You can have multiple actions per input. You can also configure different actions when a sensor is open or closed.

For example, if a window sensor is open, you can configure the system to adjust the temperature set point and disable the AC.

An external temperature sensor can be used to provide remote temperature sensing and/or temperature control. Automation control can also be configured to take necessary actions when adjustable thresholds are exceeded.

Setting Up the Sensor Inputs

The EMS Si system supports 2 sensor inputs (R1 and R2). In order to use them, you need to ensure they are correctly configured.

Name

To enable, simply enter a name for this input (i.e. Door sensor). To disable this input, delete the name.

To configure sensors and automation

From the Home screen, press **MENU**.

Select **Settings** ► **Installation Settings**.

Select **Sensors**.

Select the sensor you want to view or edit.

Configure the sensor settings as required.

To create a new action, select **Add New Action**.

Type

Defines the type of input: Dry Contact or Temperature Sensor.

If you define a temperature sensor, you will be prompted to select a manufacturer and model. If your sensor is not listed, you can add a manufacturer and model by selecting **Add New** and then configuring the follow values:

- **Manufacturer** Select an existing manufacturer or provide a name for a new one.
- **Model** Select an existing model or add a new one by defining the following sensor hardware parameters: Model Name, B Value, Compute B Value, and Temp Correction. *Consult your sensor's documentation for B and Compute B values.*

Usage

The following usage options are available for temperature sensors:

- **Control Sensor** Enables the EMS Si to use the sensor as a remote temperature sensing source. The returned temperature values can be used to control the operation of the HVAC equipment. *Automation actions are not supported with Control Sensors.*
- **Monitoring Sensor** Enables the EMS Si to perform actions when the sensor's reported temperature value goes above or below configured set points. When selected, the following custom actions appear in the Actions options:
 - **Temperature Above / Below** Performs an action when the temperature is above or below the specified set point.

- **Outdoor Sensor** Configures the EMS Si to use the sensor as an external temperature sensing source. *Automation actions are not supported with Outdoor Sensors.*
- **Discharge Air Sensor** Enables the EMS Si to perform actions when the sensor's reported temperature value goes above or below configured heating and cooling threshold values. When selected, the following custom actions appear in the Actions options:
 - **Heating Above / Below** When enabled, performs an action when the temperature is above or below the defined heating threshold.
 - **Cooling Above / Below** When enabled, performs an action when the temperature is above or below the defined cooling threshold.

Actions...

Lets you to view the current state and edit action options for a sensor. To add a new action, select **Add New Action**.

- **State** Configure if the circuit (contact) is Open or Closed.
- **Type** Select the action to perform from the list:
 - **Do Nothing** No specific action will occur.
 - **Switch to Occupied** Switches the system to the Occupied program when the input is activated.
 - **Switch to Unoccupied** Switches the system to the Unoccupied program when the input is activated.

- **Shutdown Compressor** The compressor (both for AC or Heat pump) will shutdown and remain shutdown until this input is cleared.
- **Shut down AC** The air conditioning system will shutdown and will remain shutdown until this input has cleared
- **Adjust Temperature** The heat and/ or cool set points will be adjusted by a preprogrammed amount. It will revert back to the original set point when the input has cleared.
- **Turn On Fan** The fan will be set to On. It will revert back to its original settings when the input is cleared.
- **Disable Auxiliary Heat** The auxiliary heat equipment will be disabled. It will be re-enabled when the input is cleared.
- **Shutdown All HVAC** All equipment will be disabled. It will be re-enabled when the input is cleared.
- **Disable All Heat** All heat equipment will be disabled. It will be re-enabled when the input is cleared.
- **Send Alert** Enables the system to send an alert when the input has been activated.
- **Send Update Log** Enables the system to log when this input is activated.
- **Activation Delay** Configures time delay from when the input detects the active state to when the action programmed in the Type section is performed by the system. For example, if you connect a door sensor to the input and program a 5 minute activation

delay, the door will need to open and remain open for 5 minutes before the thermostat takes action.

- **Deactivation Delay** Configures a time delay from when the input detects the inactive state to when the system reverts back to its normal operating conditions. For example, if you connect a door sensor to the input and program a 5-minute deactivation delay. The door will remain closed for 5 minutes before the thermostat will revert back to the normal operating condition.
- **Min Action Duration** Configures the minimum amount of time the system will perform this action. This timer will run its course regardless of whether the input has reverted back to its normal state and the deactivation timer has expired. This option is useful for applications where you want to run a device (i.e., fan or compressor) for a minimum amount of time after the input has been activated rather than using the deactivation delay. This ensures the fan or motor does not short cycle.

If Adjust Temperature is chosen as the Type you will also be presented with the following options:

- **Decrease Heat Temp** Allows you to program the number of degrees that the heat set temperature will be adjusted by once an input has been activated. A positive number increases the heat set point and a negative number decreases the heat set point

- **Increase Cool Temp** Allows you to program the number of degrees that the cool set temperature will be adjusted by once an input has been activated. A positive number increases the cool set point and a negative number decreases the cool set point.

In both cases this offset will apply to the set point temperature at the time of the activation of the input. As the system switches between program periods (i.e., occupied, unoccupied, etc) this offset will be maintained. Once the input has been switched back to the inactive state the set temperature will revert back to the normal limits.

- **Delete this Action** Removes the configured action.

CONNECTING TO THE INTERNET

Connect your EMS Si to the Internet so you can control it from your own personalized, secure ecobee Web Portal.

From the Web Portal, you can:

- Program, configure and control your EMS Si.
- Control your EMS Si from anywhere you have Internet access.
- Use local weather data to maximize energy savings.
- Receive important alerts and reminders about your heating and cooling system.

Note: To connect your system to your personalized ecobee Web Portal you must have a broadband Internet connection and a wireless 802.11 b/g/n (WiFi) network.

Setting Up WiFi

To set up WiFi:

From the Home screen, press **MENU**.

Select **Register Thermostat**.

Select **Continue**.

Select **WiFi Settings**.

Select **WiFi Radio ▶ Enabled**.

Select your network from the list.

If prompted, enter your network password.

The EMS Si will automatically connect to the Internet.

The EMS Si uses your WiFi network to connect to the Internet. First, enable WiFi on the EMS Si (see instructions to the right).

The EMS Si will display a list of available networks, along with an indication of the signal strength (the more bars, the better) and whether encryption is used.

If your network is not listed, or if the signal strength is very low, try adjusting the antenna on your wireless router. If that doesn't improve the signal, try moving your router closer to the EMS Si.

Once your network has been detected, select it from the list. If the network is encrypted, you will be asked to enter a password for that network. This is the password you created when the wireless router was first set up.

After you provide the password, your EMS Si will automatically connect to the Internet. A chain link on the screen indicates you have established a connection with the ecobee web servers.

Having Trouble?

If you are having trouble connecting to the Internet or finding your WiFi network, you may need to configure your network parameters manually. See WiFi on page 53.

Configuring a Web Portal Account

After setting up WiFi on your EMS Si, you need to configure your Web Portal account.

1. From a web browser on a PC, visit **www.ecobee.com**
2. Click on the **LOGIN** link.
3. Click on the **Register** link.

Note: If you already have a Web Portal account, click Login to access your account and add the thermostat from within your web portal.

4. Click the **EMS Si** link.
5. Complete the EMS account creation form.
7. Click **Submit**.

Your EMS Si is now registered. You can now monitor and control your EMS Si from the Web Portal.

USING YOUR EMS Si

The bright, easy-to-read screen on your EMS Si makes it simple to review and adjust the settings any time you want.

Adjusting the Temperature

You can easily adjust the temperature without changing the EMS Si's programming by pressing the arrow keys when the Home screen is displayed.

- Press ▲ to increase the temperature set point by 1°F (0.5°C).
- Press ▼ to decrease the temperature set point by 1°F (0.5°C).
- If the EMS Si is set to Auto mode, press ◀ to select the Cool setting.
- If the EMS Si is set to Auto mode, press ▶ to select the Heat setting.

Once you've adjusted the temperature, the screen indicates that you are currently holding the set temperature rather than running a program.

The EMS Si will hold the new temperature for the duration you specified in the Hold Action option during the initial setup (see "Hold Action" on page 47) or until you press **OK**.

If you are using Auto mode, note that there is a minimum difference allowed between heat and cool set temperatures. The system will prevent you from setting the temperatures to within these limits. See "Heat/Cool Min Delta" on page 25 for information about configuring the minimum temperature difference settings.

System Mode

This menu sets your system to use heat, cool, or auto mode:

- **Cool** The system will turn on the air conditioner when the current temperature rises above the set temperature.
- **Heat** The system will turn on the heat when the current temperature drops below the set temperature.
- **Auto** The system is in Auto-changeover mode and will activate the heating or cooling systems to keep your building within the desired range of set temperatures.
- **Auxiliary Heat Only** The system will only use the auxiliary or back-up heat source to maintain the heat set point temperature (only appears if auxiliary heat is configured).
- **Off** The system is off and will only display the current temperature.

Fan

This menu displays the current furnace fan setting:

- **On** Forces the fan to run continuously, regardless of the weekly schedule programming. The fan will also run if the system mode is Off.
- **Auto** Turns on the fan when the system is heating or cooling your building, or to satisfy the minimum fan “on” time.

When you switch between **Auto** and **ON** in fan control, the EMS Si will prompt you with the following:

To change system mode:

From the Home screen, press **MENU**.

Select **System Mode**.

Select your temperature mode: **Heat, Cool, Auto** or **Off**.

To change fan settings:

From the Home screen, press **MENU**.

Select **Fan**.

Configure your fan settings.

Hold 2 hours The fan will switch to this setting but revert back to weekly schedule after 2 hours.

Hold 4 hours The fan will switch to this setting but revert back to weekly schedule after 4 hours.

Indefinite The fan will switch to this setting and will only revert back if you do so manually .

Until Next Transition The fan will switch to this setting but will revert back when the program switches to the next period.

Update Schedule The fan will update the current schedule with this new fan setting.

After the fan mode is changed and you return to the home screen, the EMS Si will indicate that it is in a Hold state. The temperature setting will also be set to Hold. Press **OK** to revert the fan mode back to the weekly schedule fan and temperature settings.

- **Fan Min On Time** Sets a minimum amount of time per hour that the furnace fan will run. This improves air circulation and results in a more consistent temperature than with the Auto setting while being more cost-effective than the On setting. Options are from 0 to 55 min.

Weather Forecast

Displays the current outdoor temperature and weather conditions for your registered location.

Note that when you register, it's important to select your location accurately, as ecobee will use your local weather data to optimize your heating and cooling. You must register your EMS Si for this feature to operate.



To view the weather forecast:

From the Home screen, press **MENU**.

Select **Weather Forecast**.

Press **OK** to switch between the 4-day and 24-hour forecast.

Cleaning

You can clean the EMS Si's screen by spraying water or any mild, non-abrasive household cleaner on to a clean cloth. Wipe the surface of the screen with the dampened cloth.

Note: Do not spray any liquids directly onto your EMS Si.

CONFIGURING YOUR EMS Si

This section describes how to configure the personal preferences, temperature settings, and operation of your EMS Si.

Note: You can also configure your EMS Si from your personalized Web Portal. Simply open a web browser, go to ecobee.com, and log in.

Configuring Personal Preferences

To configure personal Preferences:

From the Home screen, press **MENU**.

Select **Settings** ► **Preferences**.

Adjust each option to your personal preferences.

The Preferences menu has settings for personalizing your EMS Si.

Name

You can customize the name of your EMS Si to suit your needs (i.e. Main Floor). This is useful if you have multiple systems or zones. You can view and edit your EMS Si name in the About menu on your EMS Si and also in your online Web Portal.

Date and Time

Select **Date & Time** to:

- Set the current date.
- Set the current time.
- Select a 12-hour or 24-hour time format.
- Select your time zone.
- Enable or disable daylight savings adjustments.

If you are connected to the Internet, the time and date are programmed automatically.

Brightness

The color screen has adjustable backlight brightness. You can control the intensity when the screen is active (i.e., when you are pushing buttons) and when the display is in standby mode (idle screen).

Select **Brightness** to:

- Set the Active brightness intensity.
- Set the Standby (idle screen) brightness intensity.
- Set the minimum time the EMS Si will stay in active brightness before switching to standby brightness.

Idle Screen

You can configure what information is displayed on the screen when the display is in standby mode (idle screen).

Select **Idle Screen** to:

- Enable or disable the idle screen from appearing.
- Show or hide the cool/heat set point bubbles.
- Show or hide the current time.

Hold Action

Whenever you manually adjust the set temperature, the EMS Si will indicate you are in a "Hold" mode. You can select how long the EMS Si will hold the new temperature before reverting back to the regular program:

- **Hold 2 hours**
- **Hold 4 hours**
- **Until Next transition** Thermostat will hold temperature until the next program period.
- **Indefinite** Thermostat will hold temperature until you press **OK**.
- **Update Schedule** When you adjust the set temperature, the system will update the temperature in the Weekly Schedule for the current period.
- **Ask Me** Every time you adjust the set temperature you will be asked which of the options you would like to choose.

Temperature Display

Select **Temperature Display** to select Fahrenheit (°F) or Celsius (°C).

Quick Save Settings

In Quick Save mode, your system will automatically increase (in cool mode) or decrease (in heat mode) the temperature set point by the pre-configured amount.

Quick Save mode can only be activated from the Web Portal or from the ecobee smartphone/tablet application.

Access Control

You can protect your EMS Si so that certain features will require the user to enter a 4-digit access code. Use the arrow keys to highlight a number and then press **OK**. When you are done, select **Save**. The access control will be required once the idle screen is displayed.

To disable this feature, delete the number by

selecting  multiple times.

You can also configure the level of access control:

- **Restrict All Access** Unauthorized users will only be able to view the home screen and the weather information.
- **Restrict System/Fan Access** The code is required to access the system or fan settings.
- **Restrict Program Access** The code is required to view and modify the EMS Si's Weekly Schedule.
- **Restrict Vacation Access** The code is required to view and create a Calendar Event.

In all cases, once the code is enabled, it will be required to access any of the list items in the Settings menu, with the exception of the About screen. Once a valid code has been entered on the EMS Si, access to restricted features will be allowed until the EMS Si backlight timer has expired.

Temperature Range

You can configure the EMS Si so only a specific heat and/or cool set point range is permitted.

- **Heat Min Temp** Press ▲ or ▼ select the minimum heat set point then press **OK**. Users will not be able to set the EMS Si to a temperature below this limit.
- **Heat Max Temp** Press ▲ or ▼ select the maximum heat set point then press **OK**. Users will not be able to set the EMS Si to a temperature above this limit.
- **Cool Min Temp** Press ▲ or ▼ to select the minimum cool set point and then press **OK**.

Users will not be able to set the EMS Si to a temperature below this limit.

- **Cool Max Temp** Press ▲ or ▼ to select the maximum cool set point and then press **OK**. Users will not be able to set the EMS Si to a temperature above this limit.

Recovery Options

Recovery options allow the EMS Si to learn how your heating and cooling system works, taking into account infrastructure, weather and historical operating performance so that your building is a comfortable temperature as soon as you walk in the door.

- **Smart Recovery Heat** The EMS Si will start heating at the optimum time to ensure the set point is reached at the programmed time.
- **Smart Recovery Cool** The EMS Si will start cooling at the optimum time to ensure the set point is reached at the programmed time.
- **Random Start Heat** Programming a time in this section will produce a random delay when there is call for heat. In applications with multiple heating systems, this prevents all the systems from activating at the same time (thus creating a peak power demand). Press ▲ or ▼ to select a delay time and then press **OK**.
- **Random Start Cool** Programming a time in this section will produce a random delay when there is call for cooling. In applications with multiple cooling systems, this prevents all systems from activating at the same time, (thus creating a peak power demand). Press ▲ or ▼ to select a delay time and then press **OK**.

Notes

Notes let you to enter useful information users or service contractors, such as contact information or equipment configuration. The text appears in the About screen.

Vacation Property

Places the EMS Si in a mode suitable for vacation rental properties. With this option enabled, the EMS Si will be programmed to remain in the unoccupied state (i.e., the property is vacant). The property manager can then schedule a calendar event that coincides with rental periods. During this calendar event, the ecobee EMS will switch to the occupied state. The renters will have access to features like manual adjustments and hold settings (still within the limits as programmed). Once the calendar event (i.e., rental period) has elapsed, the Thermostat will automatically revert back to the unoccupied state.

To configure utility CPP settings:

From the Home screen, press **MENU**.

Select **Settings** ► **Preferences**.

Select **Utility CPP Settings**.

Adjust each option to your preferred strategy.

Utility CPP Setting

This section is only applicable if your utility company is running a Critical Peak Pricing program that you have agreed to be a part of. Contact your local electrical utility company for information about programs in your area.

CPP Response

Your utility may send voluntary events to your EMS Si. You can choose to **Always Accept** these events. In which case, you would just be notified that an event is in progress. Or if you choose **Ask Me**, when the Utility issues an event, you will be asked if you want to participate.

If you do not acknowledge the event prior to the start, the system will default to yes.

Preferred Strategy

During a Critical Peak Pricing event the Utility may select an energy saving strategy, or allow you to use your preferred strategy. Select from one of the options as your preferred energy saving strategy to be used during Critical Peak Pricing events.

- **Absolute Temperature** Set a specific heat and cool set point to be used when an event is initiated by the Utility company. If the set point at the time of the event is more favorable (lower in heat mode or higher in cool mode) than what you have programmed, the EMS Si will use the more favorable set point for the duration of the event.
- **Relative Temperature** Program a temperature set back (heat) or set forward (cool) from your existing set point. For example, if you program a 4 °F set forward,

and your current cool set point is 76 °F, during an event your EMS Si set point will change to 80 °F until the event has expired.

- **System Off** If this option is selected, the EMS Si will turn off heating and cooling for the duration of this event.
- **Duty Cycle** This option allows you to program the maximum amount of time the system will run during a 1 hour period. For example, if you select 30%, the air conditioner will run for a maximum of 18 (0.3 x 60) minutes regardless of whether the set point has been met. 0% essentially turns the system off, whereas 100% runs the system at full capacity.

WiFi

The EMS Si supports WiFi 802.11 b/g/n. Use the Advanced Configuration option in the WiFi menu to configure your network parameters. Choose the network from the list or manually add a new one (i.e. if your network does not broadcast its SSID).

You will then be able to view and configure the following network parameters:

- DHCP (select Disabled to use a static IP Address; if unsure, leave DHCP Enabled)
- SSID
- Encryption (WEP, WEP128, WPA, or WPA2)
- Password (if encryption is used)
- WiFi Channel
- IP Address and IP Subnet

To configure WiFi manually:

From the Home screen, press **MENU**.

Select **Settings** ► **WiFi**.

Select **Advanced Configuration**.

Adjust the network options for your wireless network.

- Gateway
- Primary and Secondary DNS

If you need to specify the MAC address for the EMS Si in your router's configuration, you can obtain it from the **About** menu.

To view your weekly schedule:

From the Home screen, press **MENU**.

Select **Weekly Schedule**.

Your weekly schedule is shown on the screen.

Creating Your Weekly Schedule

Your heating and cooling needs change depending on the time of day and day of the week. For example, if there's no one in the building during the weekend, you might want to let the temperature go up in the summer, to reduce energy used by the air conditioning system, and down in the winter, to reduce heating energy.

By default, the EMS Si includes two configurable periods:

- **Occupied** Represents the period when the building or area is occupied.
- **Unoccupied** Represents the period when the building or area is unoccupied.

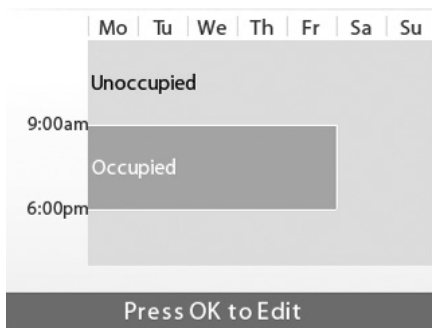

The EMS Si learns how your building's heating and cooling equipment perform. Intelligent algorithms combine weather data, your HVAC equipment run times and occupancy schedules to optimize performance and maximize energy savings.

If your schedule changes, you can quickly and easily update the EMS Si settings on the device itself or online through your Web Portal.

Using the Weekly Schedule Editor

The Weekly Schedule editor lets you to set specific times, temperatures and furnace fan settings for each day of the week.

Monday			
	Time	Heat	Cool
Occupied at	9:00 am	70°	78°
Unoccupied at	6:00 pm	62°	85°

Add New

Save and Continue

If your system is enabled for auto change-over mode, the heat and cool set temperatures will automatically be adjusted to ensure a minimum difference.

To add a new period:

Display the schedule for a day and select **Add New**.

Select **Create New Item**.

Enter a name for the new period and select **Save**.

If your building is in-use during this period, select **Yes**; otherwise select **No**.

Select **Enable**.

Select the new time and press **OK**.

The new period is added.

To schedule a calendar event:

From the Home screen, press **MENU**.

Select **Calendar Events**.

Select **Add Event**.

Enter a **Name**.

Enter the **Start** and **End** dates and times of your calendar event.

Adding New Periods

To accommodate for varying schedules, the EMS Si lets you create additional programmed periods for single or multiple days of each week. By adding a new period for a given time and day, you can specify both a heating/cooling set point and fan mode for that new period.

Disable a Period

To disable a period entirely, select the period's **Time** and then select **Disable**.

Scheduling a Calendar Event

The EMS Si's Calendar Event feature helps you conserve energy while you are away for extended periods of time. It also ensures your building is comfortable when you return.

A calendar event includes a name, start date and time, as well as the end date and time. You can enter any number of uniquely named events. Other event features to choose from include:

ecobee optimize

Select **Yes** to have the EMS Si automatically set your Heat Temperature, Cool Temperature, System Mode and Furnace Fan settings to maximize energy conservation.

Select **No** to manually configure Heat Temperature, Cool Temperature and Fan settings. These settings will be remembered the next time you create a calendar event.

Is Occupied

Select **Yes** if the building or area will be occupied during the calendar event.

Heat Temperature

Programs the set temperature when the system is in Heat mode (i.e., when the furnace is on). Set a lower temperature to save energy.

Cool Temperature

Programs the set temperature when the system is in Cool mode (i.e., when the air conditioner is on). Set a higher temperature to save energy. You can also choose to turn off your cooling system while you are away to save more energy.

Fan

Toggles the fan setting between ON and Auto.

- **ON** The fan runs all the time regardless of programming or if there is a call for heat or cool. The fan will also run if the System Mode is OFF.
- **Auto** This option turns the furnace fan on but only when the system is heating or cooling your building, or to satisfy the minimum fan run time as programmed.
- **Fan Min On Time** This feature allows you to determine a minimum time per hour that the furnace fan will run. It results in increased air circulation and a more consistent temperature within the building, and is more cost effective than choosing the ON fan setting.

In either mode, the EMS Si will ensure that when your calendar event ends, the EMS Si will revert to the regular settings.

Note: If you were running your regular program prior to the start of your calendar, on your return, the EMS Si will restore your building to those

To edit your weekly schedule:

Display your **Weekly Schedule**.

Press **OK**.

Select the **Day**.

Select the **Time, Heat or Cool Setting**.

Press ▲ or ▼ to adjust the value. Press ◀ or ▶ to toggle between columns.

Press **OK**.

Select **Save and Continue**.

Select any other days of the week that will also use the new settings. Use the navigation keys to switch between days and press **OK** to select a day.

Select **Continue**. The new schedule is displayed on the screen.

settings. If you were in Hold mode prior to the start of your calendar event, the EMS Si will restore the building to whatever the set temperature was just prior to your calendar event.

Delete Event

You can delete individual or all calendar events:

- To remove an individual calendar event, display the details about the event, then select **Delete Event ▶ Yes**.
- To remove all calendar events, display the **Calendar Event** menu and select **Delete All ▶ Yes**.

3-YEAR LIMITED WARRANTY

ecobee warrants that for a period of three (3) years from the date of purchase by the consumer ("Customer"), the ecobee EMS Si (the "Product") shall be free of defects in materials and workmanship under normal use and service. During the warranty period, ecobee shall, at its option, repair or replace any defective Products, at no charge. Any replacement and/or repaired device are warranted for the remainder of the original warranty or ninety (90) days, whichever is longer.

If the product is defective, call Customer Service at 1-877-932-6233. ecobee will make the determination whether a replacement product can be sent to you or whether the product should be returned to the following address: ecobee Customer Service, 477 Richmond St West, 2nd Floor, Toronto, Ontario, M5V 3E7, Canada. In the event of a failure of a Product, Customer may:

(a) if Customer did not purchase the Product directly from ecobee, contact the third party contractor from whom the Product was purchased to obtain an equivalent replacement product, provided the contractor determines that the returned Product is defective and Customer is otherwise eligible to receive a replacement product;

(b) contact ecobee directly for service assistance at 1-877-932-6233 and ecobee will make the determination whether an advance equivalent replacement Product can be sent to Customer with return shipping supplies (in which case a hold shall be put on Customer's credit card for the value of the replacement Product until ecobee has received the defective Product). Product should be returned to the following address: ecobee Customer Service, 477 Richmond St West, 2nd Floor, Toronto, Ontario, M5V 3E7, Canada. If the returned Product is found by ecobee to be defective and Customer is otherwise eligible to receive a replacement

product, no amount shall be charged to Customer's credit card;
or

(c) ship the defective Product directly to ecobee, in which case Customer shall contact ecobee directly at 1-877-932-6233, so ecobee can make the required shipping arrangements. Upon receipt of the defective Product, ecobee will ship an equivalent replacement product to Customer, provided the returned Product is found by ecobee to be defective and Customer is otherwise eligible to receive a replacement product.

This warranty does not cover removal or reinstallation costs and shall not apply if the damages were found to be caused by something other than defects in materials or workmanship, including without limitation, if the Product:

- was operated/stored in abnormal use or maintenance conditions;
- is repaired, modified or altered, unless ecobee expressly
- authorizes such repair, modification or alteration in writing;
- was subject to abuse, neglect, electrical fault, improper handling, accident or acts of nature;
- was not installed by a licensed Heating Ventilating and Air Conditioning (HVAC) contractor; or
- was installed improperly.

ecobee's sole responsibility shall be to repair or replace the Product within the terms stated above. ECOBEE SHALL NOT BE LIABLE FOR ANY LOSS OR DAMAGE OF ANY KIND, INCLUDING ANY SPECIAL, INCIDENTAL OR CONSEQUENTIAL DAMAGES RESULTING, DIRECTLY OR INDIRECTLY, FROM ANY BREACH OF ANY WARRANTY, EXPRESS OR IMPLIED, OR ANY OTHER FAILURE OF THIS PRODUCT. Some US states and Canadian provinces do not allow the exclusion or limitation of incidental or consequential damages, so the above limitation or exclusion may not apply to you.

ecobee's responsibility for malfunctions and defects in materials and workmanship is limited to repair and replacement as set forth in this warranty statement. All express and implied warranties for the product, including but not limited to any implied warranties and conditions of merchantability and fitness for a particular purpose, are

limited to the three-year duration of this limited warranty. No warranties, whether express or implied, will apply after the limited warranty period has expired. Some US states and Canadian provinces do not allow limitations on how long an implied warranty lasts, so this limitation may not apply.

ecobee neither assumes responsibility for nor authorizes any other person purporting to act on its behalf to modify or to change this warranty, nor to assume for it any other warranty or liability concerning this product.

This warranty gives you specific rights, and you may also have other rights which vary from jurisdiction to jurisdiction. If you have any questions regarding this warranty, please write ecobee Customer Service, 477 Richmond St West, 2nd Floor, Toronto, Ontario, M5V 3E7, Canada.

END-USER SOFTWARE LICENSE AGREEMENT

Please read the following carefully, as this end user software license agreement (“EULA”) is a legal agreement between ecobee Inc., having its place of business at 477 Richmond St West, 2nd Floor, Toronto, Ontario, M5V 3E7, Canada, (“ecobee”) and you (either an individual or the entity that you represent and referred to in this agreement as “licensee”), The original purchaser of ecobee product (The “product” or “products”) embedded with ecobee proprietary software (the “software”) concerning licensee’s limited access to and use of the software. By using the product (including the software embedded in the product), you are indicating your acceptance of, and you agree to be bound by the terms and conditions of this EULA which shall govern your access and use of the software. If you do not agree with the terms and conditions of this EULA, your access to and use of the software will not be permitted and you may, within fourteen days of the date of your purchase if the ecobee product, return the software together with the product in its original packaging and sale condition to: (a) ecobee if you have purchased the ecobee product directly from ecobee or; (b) to an ecobee authorized reseller or distributor if you have purchased the ecobee product from such entities, and ecobee or its authorized reseller or distributor as applicable shall provide a full refund of the purchase price paid within fourteen days of its receipt of the return.

In consideration of the license fees paid by LICENSEE as part of the purchase price of the ecobee Product and the mutual covenants contained herein and for other good and valuable consideration, the receipt and sufficiency of which are hereby acknowledged, ecobee and LICENSEE agree as follows:

- 1. Definitions:** For the purpose of this EULA, the following terms shall have the meanings hereinafter provided:

“ecobee Web Portal” means the web site portal operated by ecobee to provide

certain services and functionality to registered users of ecobee Products.

“Error” means any program defect, error, bug or other failure of all or part of the Software that results in the Software not conforming to, or performing in accordance with, its published specifications.

“Software” means ecobee’s computer software program, which enables data upload and download to and from the ecobee Web Portal using an ecobee Product, including any Software Updates.

“User Manual” means the ecobee User Manual provided together with the Product and Software.

“Software Updates” means updates or patches to the Software, including updates intended to correct Errors and which may include enhancements and/ore additional features to the Software, as may be provided or released by ecobee from time to time to all of its customers at no charge.

- 2. Ownership of Software:** LICENSEE acknowledges and agrees that, save and except for the Software license explicitly granted by the EULA, all right, title and interest in and to the Software and the User Manual is the sole and exclusive property of ecobee and/or its licensors), as the case may be. ecobee reserves all rights not expressly granted to LICENSEE hereunder, and for greater certainty, ecobee shall retain all intellectual property and other proprietary rights in and to the Software and the User Manual. Nothing in this EULA shall, or shall be deemed or construed to, assign, transfer or convey to LICENSEE any title, rights or interest in or to any intellectual property, including in or to the Software or User Manual, other than the licenses specifically and expressly granted herein.
- 3. Grant of Limited License:** Upon LICENSEE’s use of the Product (and corresponding acceptance of the terms and conditions of this EULA), ecobee hereby grants to LICENSEE a limited, non-exclusive, personal, perpetual, non-transferable and revocable license to use the Software embedded in the Product as and to the extent described in this EULA for as long as LICENSEE complies with the terms and condition of this EULA. ecobee reserves all rights not expressly granted to LICENSEE. For certainty, this EULA does not apply to or govern LICENSEE’s use of or access to the ecobee Web Portal or the ecobee Product, which are each governed by and subject to separate terms and conditions.
- 4. Permitted Use:** Pursuant to the Software license granted to LICENSEE under this EULA, LICENSEE shall be permitted to: (a) use the Software embedded in the Product for the purposes of using the Product only as intended and contemplated by the User Manual, provided that the Software may only be used for its personal and private use in connection with the use of the Product; and (b) use the User Manual provided by ecobee solely as is necessary to operate and use the Software and ecobee Product as and to the extent permitted thereunder and under this EULA.

5. **License Transferable:** This EULA shall be binding upon and shall ensure to the benefit of and be enforceable by each of the parties, their respective successors and permitted assigns. LICENSEE may assign this EULA without the prior consent of ecobee. ecobee may assign this EULA without the consent of LICENSEE at any time.
6. **Copy Restrictions:** Unauthorized copying or distribution of Software or the User Manual is expressly prohibited. LICENSEE may make a reasonable number of copies of the User Manual to the extent reasonably required for its use of the Software and Product as permitted by this EULA; provided that LICENSEE may not use the User Manual separately from the Product or Software or for any purpose other than as contemplated herein.
7. **Use Restrictions:** LICENSEE may not: (a) modify, adapt or otherwise change the Software or in any way remove the Software from the Product for any reason or use the Software separately from the Product for any reason or purpose; (b) to the maximum extent permitted to be restricted by applicable law, reverse engineer, decompile, disassemble, or otherwise in any manner deconstruct all or any part of the Software; (c) create derivative works based on the Software or the User Manual; (d) except as expressly permitted by the EULA, provide, disclose, sublicense, distribute, transfer, assign or otherwise permit any third party to access, use, read or otherwise gain access to the Software or User Manual (the Software and User Manual being the confidential information of ecobee); or (e) use Software to access or in conjunction with any other thermostat monitoring services or products of any ecobee competitor.
8. **Support:** ecobee may in its discretion, without any obligation to do so and subject to the limitations of this EULA, provide LICENSEE with help-desk telephone support concerning LICENSEE's use of the SOFTWARE to the extent provided for in the Product Terms of Sale in connection with purchase and sale of the Product and the Terms of Service entered into by you and ecobee, if any, in connection with the thermostat monitoring and data management services provided by ecobee in connection with the Product. Refer to the Product Terms of Sale and/or the Terms of Service associated with the Product and related services for further details on Software and Product support.
9. **Relief:** LICENSEE agrees that damages would not be an adequate remedy for any breach of this EULA affecting or related to a breach or misappropriation of ecobee' (or its or its third party licensors') intellectual property rights in and to the Software and User Manual. LICENSEE, and nothing in this EULA, shall interfere with, delay, obstruct, or prevent ecobee from taking, or require ecobee to take, any steps prior to taking action to seek an interim and interlocutory equitable remedy on notice or ex parte to enforce any provision herein to protect its rights concerning the Software or other intellectual or proprietary rights. LICENSEE agrees not to contest, object to, or otherwise oppose an application for equitable relief by ecobee in such circumstances and LICENSEE waives any and all immunities from any equitable relief to which it may be entitled. Any such relief or remedy shall not be exclusive, but shall be in addition to all other available legal or equitable remedies. LICENSEE agrees that the

provisions of this Section are fair and reasonable and are necessary to protect ecobee's intellectual property rights.

10. Termination: This EULA is effective until and unless terminated. Subject to Section 13, this EULA will terminate automatically if LICENSEE fails to comply with any provision of the License. If LICENSEE is a business entity or other entity, any failure to comply with the terms and condition of this EULA by any individual employed or engaged by such entity will be deemed a failure to comply by LICENSEE. Upon any termination, LICENSEE shall destroy all copies of Software and User Manual.

11. Warranty: (a) ecobee shall provide its standard Product and Software limited warranty statement ("Customer Warranty"), which equally applies to the Software embedded in the Product, and which is incorporated by reference herein, with the Product for your benefit only. In the event of an Error in connection with the Software, refer to the Customer Warranty and Terms of Sale provided with the Product for further detail. (b) EXCEPT FOR THE REPRESENTATIONS, WARRANTIES, AND COVENANTS EXPRESSLY CONTAINED IN THIS EULA, THE PRODUCT TERMS OF SALE AND THE PRODUCT WARRANTY, THE SOFTWARE AND SOFTWARE DOCUMENTATION AND ANY SUPPORT IS PROVIDED ON AN "AS IS" BASIS, AND THERE ARE NO OTHER REPRESENTATIONS, WARRANTIES, COVENANTS, OR CONDITIONS, EXPRESS OR IMPLIED (INCLUDING ANY IMPLIED WARRANTIES OR CONDITIONS OF MERCHANTABILITY OR FITNESS FOR A PARTICULAR PURPOSE AND THOSE ARISING BY STATUTE OR OTHERWISE IN LAW OR FROM A COURSE OF DEALING OR USAGE OF TRADE), INCLUDING, BUT NOT LIMITED TO, NON-INFRINGEMENT, CORRECTNESS, FUNCTIONALITY, RELIABILITY, ACCURACY, CURRENTNESS, OPERATION, USE OR THE RESULTS OF THE USE BY LICENSEE, THAT THE OPERATION OF THE SOFTWARE WILL BE UNINTERRUPTED OR ERROR-FREE (OR THAT ALL ERRORS CAN OR WILL BE CORRECTED) OR THAT THE SOFTWARE OR SOFTWARE DOCUMENTATION WILL MEET LICENSEE'S REQUIREMENTS, ALL OF WHICH ARE EXPRESSLY DENIED AND DISCLAIMED TO THE MAXIMUM EXTENT PERMITTED BY LAW. SOME JURISDICTIONS DO NOT PERMIT LIMITATIONS ON OR EXCLUSIONS OF CERTAIN IMPLIED WARRANTIES, OR THE EXCLUSION OR LIMITATION OF CERTAIN DAMAGES; THEREFORE THE ABOVE LIMITATIONS MAY NOT APPLY TO YOU IN CERTAIN CIRCUMSTANCES. ecobee DISCLAIMS AND SHALL HAVE NO LIABILITY TO LICENSEE FOR ANY AND ALL ACTS OF THIRD PARTIES. NO OTHER PERSON IS AUTHORIZED TO EXTEND, VARY OR TRANSFER ANY PROVIDED WARRANTY ON BEHALF OF ecobee. THE ENTIRE RISK AS TO THE RESULTS AND PERFORMANCE AND USE OF THE SOFTWARE, SOFTWARE DOCUMENTATION AND ANY PROVIDED SUPPORT IS ASSUMED BY LICENSEE.

12. Limitation: IN NO EVENT AND TO THE MAXIMUM EXTENT PERMITTED UNDER APPLICABLE LAW SHALL ECOBEE, ITS SHARE-HOLDERS, AFFILIATES, CONTRACTORS, SUPPLIERS AND AGENTS AND THEIR RESPECTIVE DIRECTORS, OFFICERS AND

EMPLOYEES (COLLECTIVELY THE “ECOBEE PARTIES”) BE LIABLE TO LICENSEE OR ANY THIRD PARTY FOR ANY INDIRECT, INCIDENTAL, EXEMPLARY, SPECIAL, PUNITIVE OR CONSEQUENTIAL DAMAGES (INCLUDING WITH RESPECT TO LOSS OF, OR DAMAGE TO, DATA OR COMPUTER SYSTEMS OR RELIANCE ON ANY DATA DERIVED FROM LICENSEE’S USE OF THE SOFTWARE, OR LOSS OF REVENUE OR PROFIT OR OTHER ECONOMIC LOSS) OF ANY KIND OR NATURE WHATSOEVER SUFFERED BY LICENSEE OR ANY THIRD PARTY HOWSOEVER CAUSED AND WHETHER RESULTING FROM THE USE OF OR INABILITY TO USE THE SOFTWARE OR OTHERWISE (INCLUDING AS A RESULT OF OR DUE TO USE OF OR RELIANCE ON THE SOFTWARE AND/OR ecobee WEB PORTAL) AND REGARDLESS OF THE FORM OR CAUSE OF ACTION, EVEN IF SUCH DAMAGES ARE FORESEEABLE OR ecobee HAS BEEN ADVISED OF THE POSSIBILITY OF SUCH DAMAGES. ECOBEE PARTIES’ TOTAL LIABILITY AND OBLIGATION TO LICENSEE, IN THE AGGREGATE FOR ANY AND ALL CLAIMS ARISING OUT OF OR IN ANY CONNECTION WITH THIS EULA, THE TERMS OF SALE IN CONNECTION WITH YOUR PURCHASE OF THE PRODUCT AND YOUR USE OF THE SOFTWARE AND PRODUCT, WITH RESPECT TO ANY EXPENSE, DAMAGE, LOSS, INJURY, OR LIABILITY OF ANY KIND, REGARDLESS OF THE FORM OF ACTION OR THEORY OF LIABILITY (INCLUDING FOR BREACH OF CONTRACT, TORT, NEGLIGENCE, BY STATUTE OR OTHERWISE) SHALL BE LIMITED TO THE ACTUAL DIRECT DAMAGES SUFFERED AND SHALL NOT EXCEED AN AMOUNT THAT IS EQUIVALENT TO THE PURCHASE PRICE OF THE ecobee PRODUCT ACTUALLY PAID BY LICENSEE. THIS SECTION SHALL SURVIVE A FUNDAMENTAL BREACH OR BREACHES AND/OR FAILURE OF THE ESSENTIAL PURPOSE OF THE AGREEMENT.

13. **Survival:** The parties acknowledge and agree that the provisions of Sections 2, 6, 7, 9, 11(b), 12, 13, 14, 15, 16 and 17 shall survive any termination of this EULA for any reason.
14. **English Language:** The parties declare that they have required that this agreement and all documents related hereto, either present or future, be drawn up in the English language only. Les parties déclarent par les présentes qu’elles exigent que cette entente et tous les documents y afférents, soit pour le présent ou le futur, soient rédigés en langue anglaise seulement.
15. **Jurisdiction:** This EULA shall be exclusively governed by, construed and interpreted in accordance with the laws of the Province of Ontario, Canada. For the purpose of all legal proceedings this EULA shall be deemed to have been performed in the Province of Ontario, Canada and the parties expressly confirm that the law of the Province of Ontario is the proper law. If Customer is located in a jurisdiction other than Canada, the parties agree that neither the United Nations Convention of the International Sale of Goods or the (U.S.) Uniform Computer Information Transactions Act shall apply to this EULA. The parties irrevocably attorn to the non-exclusive jurisdiction of the Courts of the Province of Ontario in respect of all matters and disputes arising hereunder.
16. **Export Law Assurances:** LICENSEE acknowledges that the Software may be subject

to export and import control laws, and agrees to comply fully with those laws in connection with the Software.

- 17. General Provisions:** No delay or omission by ecobee to exercise any right or power it has under this EULA or to object to the failure of any covenant of LICENSEE to be performed in a timely and complete manner, shall impair any such right or power or be construed as a waiver of any succeeding breach or any other covenant. Any waivers by ecobee must be in writing and signed by an authorized representative of ecobee. If any provision of this EULA is held by a court of competent jurisdiction to be invalid or unenforceable in any respect, then the remaining provisions of this EULA, or the application of such provisions to persons or circumstances other than those as to which it is invalid or unenforceable shall not be affected thereby, and each such provision of this EULA shall be valid and enforceable to the extent granted by law. The EULA constitutes the entire agreement between the parties as it relates to the license and use of the Software and User Manual and the subject matter of this EULA and supersedes all prior or contemporaneous agreements, negotiations, representations and proposals, written or oral between ecobee and LICENSEE. The EULA may only be amended or supplemented by written agreement executed by each of the parties.

