

# Generator Start Control Module

Part# GSCM-WIFI



**ATKINSON ELECTRONICS, INC.**

14 West Vine Street · Murray, Utah 84107

Contact [cbdsales@atkinsonel.com](mailto:cbdsales@atkinsonel.com) for the proper hookup diagram. Please include the generator make & model, inverter brand, & battery bank voltage.

# Table of Contents

Features & Applications .....	3
Description.....	3
Modes of Relay Operation .....	4
Operational Sequence Example .....	5
Terminal Pin Descriptions .....	6
Terminal Pin Descriptions (cont.).....	7
LED Indication Description .....	8
Adjustable Operational Settings .....	9
Wireless Configuration Page .....	10
Wireless Configuration Page Description .....	11
Wireless Configuration Descriptions (cont.) .....	12
Wireless Configuration (cont.) .....	13
Wireless Configuration (cont.) .....	14
Power and Start Signal Wiring Diagrams .....	14
Power and Start Signal Wiring Diagrams (cont.).....	16
Starting/Shutdown Circuit Wiring Examples.....	17
K3 Option Wiring Examples .....	18
Generator Recommended Presets.....	19
Preset Defaults.....	20
Resetting Defaults.....	21
Specifications .....	22
Limited Warranty .....	23

## Features & Applications

---

- 2-wire to 3 or 4-wire start controller for electric start 3 or 4-wire gas, propane, or diesel generators
- Supports many types of 3 or 4 wire generator control: Momentary, Pulse, Ignition, Glow Plug, Prime, Load Control, etc.
- Wifi interface for making changes to adjustable configuration options.
- Adjustable crank time, delay, and attempts.
- Adjustable battery voltage monitoring thresholds
- ABS case and conformal coating for harsh environment operation

### Description

The GSCM-Wifi is a micro-controller-based generator start-stop module, designed to automatically start and stop generators that need a 3 or 4-wire connection when the start command is from a 2-wire signal (12VDC or dry contact). The GSCM-Wifi automatically disconnects the starter when it receives a remote start indication lamp signal (12VDC connected to terminal 5) or an AC Hz signal from the generator (AC connected to terminals 6 & 7). Various LEDs will flash or turn on to indicate the run or fault status of the GSCM-Wifi. If a fault has occurred, manually resetting the GSCM-Wifi by removing and then reconnecting the power removes any lockout and returns it to normal operation.

The GSCM-Wifi is powered by 12VDC from the generator battery. It can monitor the battery voltage and start the generator to charge that battery if it is also connected to terminal 3. Alternatively, terminal 3 can be connected to a battery bank of 12, 24, or 48 volts. The GSCM-Wifi can be configured to start and stop the generator at selected voltage levels.

## Modes of Relay Operation

---

There are many different options for the GSCM-WIFI's three relay contacts to be configured:

Relay #1 (K1): K1 cranks the starter on the generator or sends a pulsed start signal. The maximum crank time is adjustable from 1 to 30 seconds. If set to 4 seconds or less, it acts as a pulse signal. When set to 5 or more seconds, it acts as a traditional starter crank.

Relay #2 (K2): K2 is most often used to activate a shutdown circuit (momentary pulse or constant) or as an ignition switch. It can also be configured to act as a "Glow/Stop" or "Prime/Stop" for RV style generators that have a prime on the stop button. In some configurations (typically when K1 is a pulse for both start and stop) K2 will be set to "None" and will not be used in that case.

Relay #3 (K3): K3 can be configured to perform a variety of functions. It can act as an ignition or battery switch, configured to control a glow plug or prime circuit, or set up to control an external choke control actuator/solenoid or "Load Control" relay. If K3 is not required for any function it can be left disabled.

## Operational Sequence Example

---

The following is an example of a typical sequence of operations for the GSCM-Wifi when starting a generator.

1. The GSCM-Wifi will be in an idle state. The “Start” light will be blinking slowly.
2. When a start signal is received on terminal 4 the “Start” light will turn on.
3. If relay 2 is configured to be a power switch, then it will activate, and the K2 light will turn on.
4. After 2-3 seconds, relay 1 will activate and the K1 light will turn on. This will crank the starter in the generator.
5. Once the generator starts, relay 1 will deactivate and the K1 light will turn off.
6. The “Run” light will then turn on.
7. The GSCM-Wifi will now be in an active state.
8. When the start signal is turned off on terminal 4 the “Run” light will turn off.
9. If relay 2 is configured as a power switch, then it will deactivate, and the K2 light will turn off. If relay 2 is configured to control a stop circuit, then it will activate for a few seconds. This will shut down the generator.
10. The “Start” light will return to a slow blink and the GSCM-Wifi will return to an idle state.

Most generator configurations will use a sequence very similar to this. However, due to the number of settings available, there are dozens of possible operation sequences.

## Terminal Pin Descriptions

---

The GSCM-Wifi has 14 terminal pins(tabs). The function of each is as follows:

- 1) Battery (-) Neg – Primary power connection to the negative terminal on the generator battery. Any chassis ground should also be suitable if the chassis is also properly connected to the negative post of the battery.
- 2) Battery (+) Pos – Primary power connection to the positive (12V) terminal of the generator battery. The GSCM-Wifi can be powered from any 12V source, but the generator battery is greatly preferred.
- 3) Battery Sense – Optional connection to monitor the voltage of a battery or battery bank. This terminal cannot be connected to a source above 60 volts. Doing so will cause damage to the GSCM-Wifi.
- 4) Start Signal – Connecting this terminal to 12VDC signals the GSCM-Wifi to attempt to start and run the generator.
- 5) Gen DC Feedback – Applying 12VDC to this terminal tells the GSCM-Wifi that the generator is running. \*
- 6) AC feedback (L1) – Connect to the L1 (hot) wire of the generator AC output. Used with terminal 7 for AC feedback. Allows the GSCM-Wifi to detect that the generator is running. \*
- 7) AC Feedback (N) – Connect to the neutral wire of the generator AC output. Used with Terminal 6 for AC Feedback\*

\*When selecting a feedback method use either the DC feedback on terminal 5 or use the AC feedback on terminal 6 and 7. Do not use both at the same time.

## Terminal Pin Descriptions (cont.)

---

- 8) Relay 1 (K1) COM – the common contact of K1.
- 9) Relay 1 (K1) N/O – the normally open contact of K1.
- 10) Relay 2 (K2) COM – the common contact of K2.
- 11) Relay 2 (K2) N/O – the normally open contact of K2.
- 12) Relay 3 (K3) COM – the common contact of K3.
- 13) Relay 3 (K3) N/C – the normally closed contact of K3.
- 14) Relay 3 (K3) N/O – the normally open contact of K3.

When using the AC feedback on terminal 6 and 7, it is absolutely necessary to use insulated connectors on the wires. Failure to do so can lead to a shock hazard due to the exposed AC line connection on a non-insulated connector.

The terminal pins on the GSCM-Wifi are ¼” male quick-connect tabs. Connections should be made using insulated female quick-connect terminals. Quick-connect terminal connectors are not included with the GSCM-Wifi. However, connector kits can be found easily through major online retailers or in the electrical supply section of home improvement or automobile parts stores.

## LED Indication Description

---

The GSCM-Wifi has nine indication LEDs.

The Power LED indicates when a suitable 12-volt power supply has been connected to terminal 1 (ground) and terminal 2 (positive).

The Start LED blinks once every 5 seconds to indicate it is ready for a start signal. The LED will blink once every second to indicate the generator is running in battery charge mode. On continuously indicates the generator is running due to an external request on the Start Signal terminal (tab 4).

The Gen Status LED indicates fault conditions or generator status:

- Slow blink: indicates an under-Hz condition.
- Fast blink: indicates an over-Hz condition.
- Double blink: indicates a start failure condition.
- Four blinks indicate generator shut down due to its own fault condition or lack of fuel.
- Five blinks indicate the generator did not shut down after a stop signal was sent.
- On continuously: indicates AC or DC feedback present meaning the generator was started and is running externally from the GSCM-Wifi.

The Run LED, when on, indicates the GSCM-Wifi started the generator and that it is now running.

The Fault LED, when on, indicates a fault condition has occurred and the GSCM-Wifi is in lockout and must be reset.

The K1, K2, and K3 LEDs indicate the relay status.

The WIFI LED, when on, indicates the built-in wireless network is active.

## Adjustable Operational Settings

---

These settings are all changed or set via the GSCM-Wifi wireless network connection. The descriptions for these can be found starting on page 11.

Crank time:	1-30 seconds
Crank Delay:	5-120 seconds
Crank Attempts:	1-10 attempts
Relay 3 (K3) Timing:	1-255 seconds
Relay 3 (K3) shutoff delay:	0-20 seconds
Minimum Battery Charge time:	0-255 minutes
Maximum Battery Charge time:	60-720 minutes
Battery Charge Low voltage:	10-60 volts
Battery Charge High Voltage:	10-60 volts
Battery Charge Limit Voltage:	10-60 volts
Battery Charge Start Delay:	0-1200 seconds
Battery Charge End Delay:	0-1200 seconds
AC Hz tracking:	On or Off
Under Speed Cutoff:	40Hz – 70Hz
Over Speed Cutoff:	50Hz – 80Hz
Nominal AC Hz:	50Hz, 60Hz, or 255 Hz
Crank Cutoff Hz:	30Hz to 200Hz
WIFI Timeout:	5-60 minutes

- Relay 2 (K2) functions:
- Shutdown circuit
  - Ignition switch
  - Glow/Prime and Stop

- Relay 3 (K3) Functions:
- Glow Plug control
  - Ignition switch
  - Battery switch
  - Fuel Prime control
  - Load control
  - Choke control

# Wireless Configuration Page

---

The Wi-Fi configuration and setup page can be activated by pressing the WIFI TOGGLE button on the front face of the GSCM-Wifi. Once activated, a wireless network named “gscm\_wifi” will appear in the list of available networks on any mobile phone or wireless enabled PC. Once connected to that network the configuration page can be accessed by directing the web browser on the device to the following address: 192.168.4.1. The configuration page should then appear as shown in figure 1.

Figure 1 – Image does not show all options

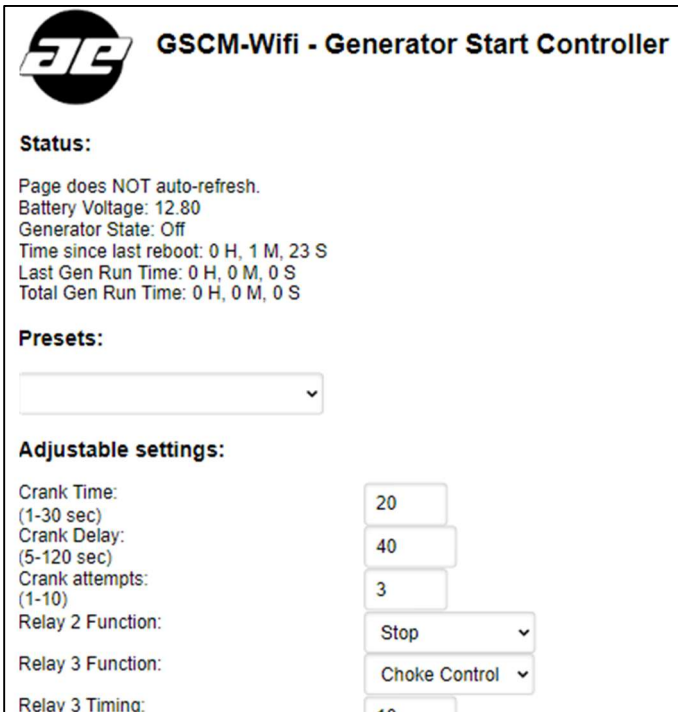

**GE** GSCM-Wifi - Generator Start Controller

**Status:**

Page does NOT auto-refresh.  
Battery Voltage: 12.80  
Generator State: Off  
Time since last reboot: 0 H, 1 M, 23 S  
Last Gen Run Time: 0 H, 0 M, 0 S  
Total Gen Run Time: 0 H, 0 M, 0 S

**Presets:**

**Adjustable settings:**

Crank Time: (1-30 sec)	<input type="text" value="20"/>
Crank Delay: (5-120 sec)	<input type="text" value="40"/>
Crank attempts: (1-10)	<input type="text" value="3"/>
Relay 2 Function:	<input type="text" value="Stop"/>
Relay 3 Function:	<input type="text" value="Choke Control"/>
Relay 3 Timing:	<input type="text" value="10"/>

## Wireless Configuration Page Description

---

The following is an explanation of the information and options available on the configuration page.

**Status:** Shows the following items:

- Operational state of the generator.
- Battery voltage (If connected on terminal 3)
- Time elapsed since the GSCM-Wifi has been powered on.
- AC Hz and current run time (If generator is running)
- The last generator run time and the total run time. There is a link provided to reset the total run time if needed.

If a fault has occurred, a note will show the reason for the lock-out. In that case, there will be a link to reset the GSCM-Wifi.

**Presets:** Allows the user to select from many of the previous non-configurable GSCM products from Atkinson Electronics. Selecting one of the options will change the settings on the page to match the settings that had been hard coded into that model.

**Adjustable settings:** All the options which can be changed are found here. Each one is explained individually below:

- **Crank time:** The amount of time to keep relay 1 (K1) active to either pulse the start circuit (1-4 seconds) or engage the starter motor (5-30 seconds). If set to pulse, an extra option will appear that sets if it is a single or double pulse.
- **Crank Delay:** The time to wait between crank attempts. Also sets the time to wait between attempts to turn off the generator if the crank relay is set to pulse mode.
- **Crank Attempts:** The number of times the GSCM-Wifi will try to start the generator before going into a fault.

## Wireless Configuration Descriptions (cont.)

---

- **Relay 2 Function:** selects the function of relay 2 (K2).
- **Relay 2 Stop hold time:** If K2 is set to “Stop” or “Glow/Stop”, this option will appear for setting how long the relay is held after the generator has stopped running.
- **Relay 2 Glow timing:** If K2 is set to “Glow/Stop”, the stop hold time option will appear as well as an option to set how long the relay is engaged as a glow plug signal before cranking.
- **Relay 3 Function:** selects the function of relay 3 (K3)
- **Relay 3 Timing:** This option will only display if the selected K3 function requires it. Sets the time K3 is active before cranking for glow, prime, or choke control operations. Also used to set the delay time on the load control option.
- **Relay 3 Shutoff delay:** only displays if the K3 function is set to Glow Plug or Choke Control. Sets the time delay for turning off K3 after the generator has started (Glow Plug) or after cranking started (Choke Control).
- **Min Battery Charge time:** the minimum time, in minutes, the generator should run if in battery charge mode.
- **Max Battery Charge time:** the maximum time, in minutes, the generator can run if in battery charge mode.
- **Battery Cut-In Voltage:** the GSCM-Wifi will switch to battery charge mode below this voltage.
- **Battery Cut-Out Voltage:** the high-end voltage target where the GSCM-Wifi will end the battery charge mode.
- **Battery Voltage Limit:** if the monitored battery reaches this voltage while the generator is running in battery charge mode, the GSCM-Wifi will immediately shut down the generator.
- **Battery Low delay:** the time, in seconds, that the GSCM-Wifi will wait before starting the generator when the monitored battery drops below the Battery cut-in voltage.

## Wireless Configuration (cont.)

---

- **Battery High delay:** the time, in seconds, that the GSCM-Wifi will wait before shutting down the generator when the monitored battery has been charged to above the Battery cut-out voltage.
- **AC Hz Tracking:** turns on or off the under-speed and over-speed tracking of the AC frequency output of the generator if using the AC feedback (tabs 6&7)
- **Under Speed Cutoff:** If Ac Hz Tracking is enabled and the generator AC Hz output drops below this value for more than 10 seconds, the GSCM-Wifi will go into an under-speed fault.
- **Over Speed Cutoff:** If Ac Hz Tracking is enabled and the generator AC Hz output goes above this value for more than 10 seconds, the GSCM-Wifi will go into an over-speed fault.
- **Nominal AC Hz:** the typical AC frequency for the generator
- **Crank Cutoff Hz:** The AC Hz at which to stop cranking the starter.
- **Wifi Timeout:** the time to wait, in minutes, to automatically turn off the wireless connection after it has been turned on.

Once the desired changes have been made, pressing the Save button at the bottom of the list will send the settings to the GSCM-Wifi. The settings will be stored in memory and reloaded if the GSCM-Wifi is rebooted. Most settings will take effect the next time a request is made to the GSCM-Wifi to start the generator. It is recommended to change the settings only when the generator is off. Changing the settings while the generator is running can lead to unexpected and possibly undesired behavior.

If the settings entered for any of the battery voltages fall outside the correct range for the actual battery or battery bank, then the battery voltage settings will reset to their defaults.

# Wireless Configuration (cont.)

Most of the settings have a limited range for the values that can be entered. The web form will not allow entries to be made outside of that range. Also, there are some combinations of settings which would cause the GSCM-Wifi to operate incorrectly. As such, the web page interface will warn the user if one of those combinations is attempted.

## Power and Start Signal Wiring Diagrams

Figure 2 – Battery and Relay Style (Dry Contact) Inverter Wiring

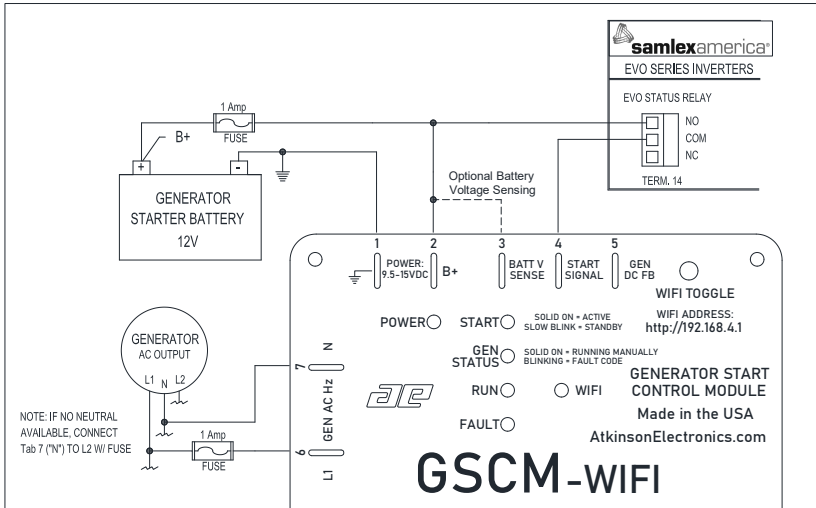

This drawing is used for any inverter or dry contact that is NOT an Outback FX. This includes Victron, Samlex, and Outback Radian inverters.

# Power and Start Signal Wiring Diagrams (cont.)

Figure 3 – Battery Power and Outback FX Inverter Wiring

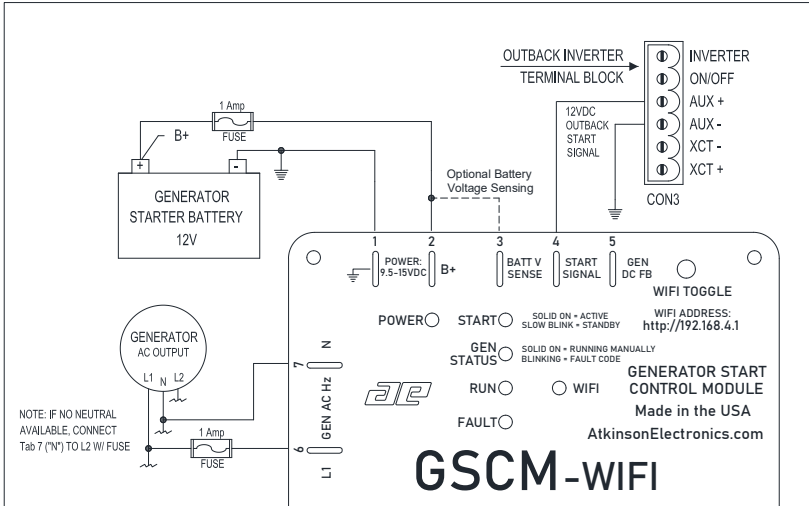
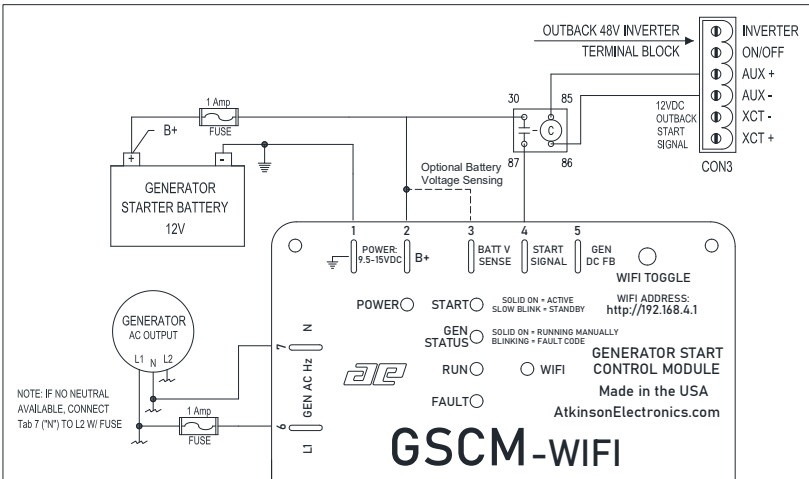

Figure 4 – Battery and Outback FX Inverter (48 Volt Battery Bank)



When using an Outback FX inverter on a 48-volt battery bank, an external isolation relay is required. This is due to the differences that can arise in the levels of the ground potential between the generator battery and the battery bank. The 12-volt signal from the Outback FX activates the relay.

# Power and Start Signal Wiring Diagrams (cont.)

Figure 5 – Battery Power and Battery Bank wiring

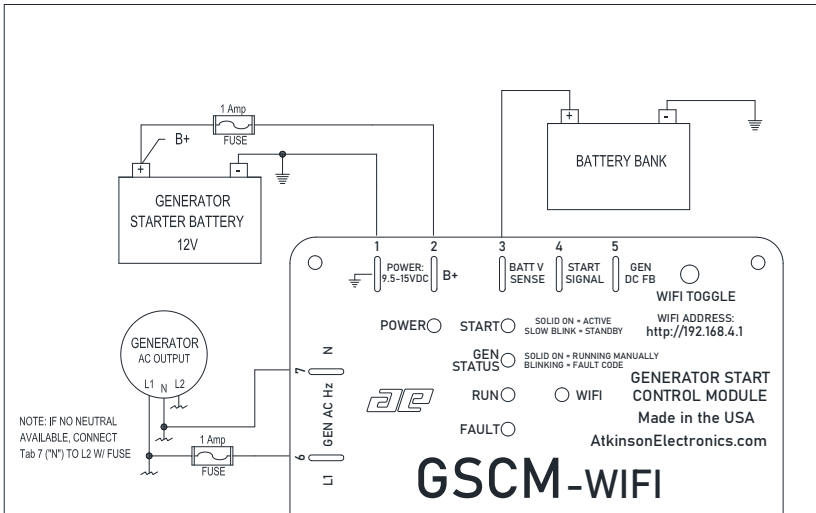

When no inverter is being used to send a signal, the GSCM-Wifi can be used to monitor the battery bank directly. The GSCM-Wifi can monitor a 12-, 24-, or 48-volt battery bank.

**Important note for all hookup types:** Terminal 1 connects to the negative post on the generator battery. When using an inverter or external battery bank, also make sure the negative connections for those are also well connected to ground on the generator. Doing so will prevent the ground connections from “floating”.



### **Not Included.....**

Outback 48-volt inverter systems require isolation relay A0365

# Starting/Shutdown Circuit Wiring Examples

Figure 6 - Onan HDKxx (QD series)

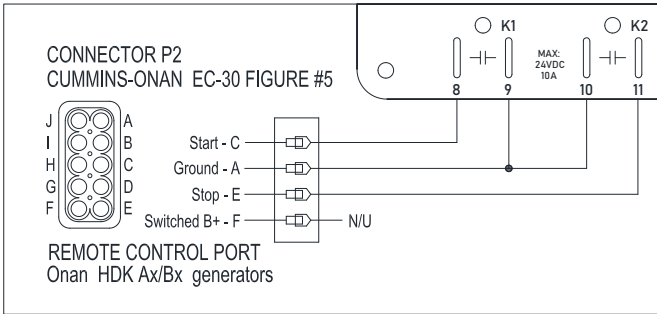

Figure 7 - Onan HGJxx or KVx (RV Gas/Propane generators)

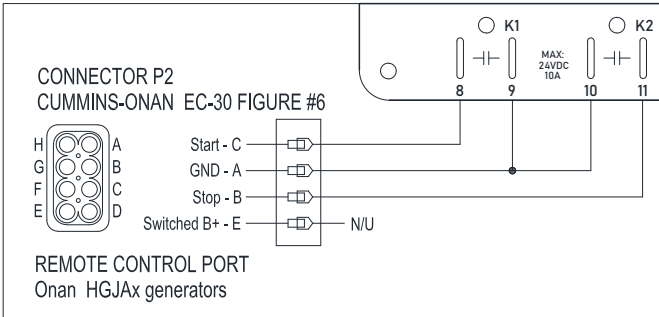
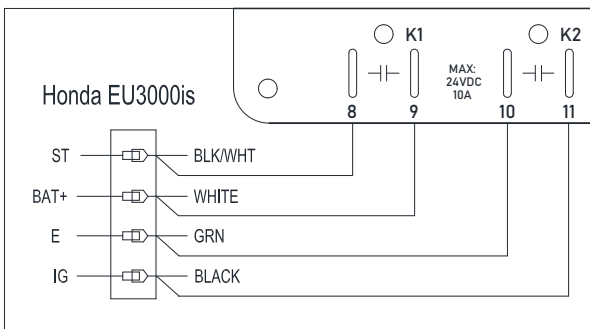

Figure 8 - Honda EU3000IS



These drawings are only examples. It is recommended to obtain a full wiring diagram from Atkinson Electronics for whichever generator is being used.

## K3 Option Wiring Examples

Figure 9 - Prime Valve

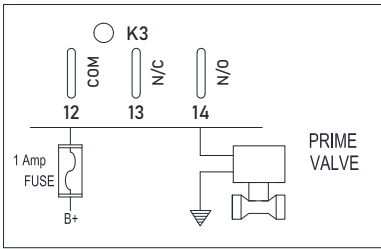

The GSCM-Wifi's K3 relay is configured for prime valve control and is wired in series with the prime valve and Battery (+). The K3 timing setting sets how many seconds the prime will be active before trying to start.

Figure 10 - Choke Actuator

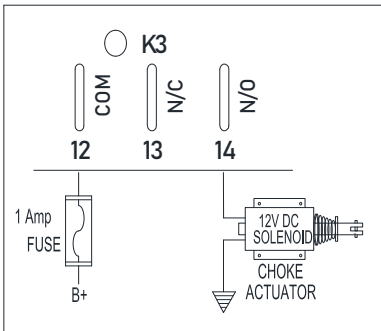

The GSCM-Wifi's K3 relay is configured for choke control and is wired in series with the choke actuator/solenoid and Battery (+). The K3 timing setting sets how many seconds before starting that the choke will be activated. The K3 Shutoff Delay setting sets the number of seconds to wait to deactivate the choke after cranking starts.

Figure 11 - Load Control

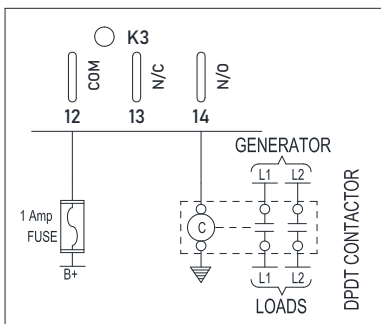

The GSCM-Wifi's K3 relay is configured for Load Control and is wired in series with the coil on the contactor and Battery (+). The K3 timing setting sets how many seconds after starting or before shutdown that the contactor will be activated or deactivated.

## Generator Recommended Presets

---

The following table is a list of the most common generators used with the GSCM product line. The recommended setting preset for each is shown in the adjacent column.

<b>Generator Make and Model</b>	<b>Preset</b>
Champion 100165	GSCM-Mini-60
Champion 100297	GSCM-Mini-60
Champion 100520i	GSCM-Mini-P
Duromax XP4400E	GSCM-Mini-60
Duromax XP9000iH	GSCM-Mini-P
Duromax XP10000EH	GSCM-Mini-60
Firman H, P, or T series	GSCM-Mini-60
Generac GP series	GSCM-Mini-60
Generac QP series	GSCM-Mini-D
Generac XT series	GSCM-Mini-60
Honda EM, EU, or GX series	GSCM-Mini-60
Kohler 11EKOZD	GSCM-Mini-P
Kohler 15-20EORZ	GSCM-Mini-D
Kohler EOZD	GSCM-Mini-P
Kubota GL series	GSCM-Mini-3R (Glow Plug)
Northern Lights NL673	GSCM-Mini-D
Onan 7.5-15JB or JC	GSCM-Mini-60
Onan HDKxx	GSCM-Mini-O
Onan HGJxx	GSCM-Mini-60
Onan HGJxx(w/ prime)	GSCM-Mini-D
Onan MDKxx	GSCM-Mini-O
Onan P9500df	GSCM-Mini-P
Westinghouse iGen4500	GSCM-Mini-P
Westinghouse WGen series	GSCM-Mini-P
Winco (all models)	GSCM-Mini-60
Yamaha EF series	GSCM-Mini-60

## Preset Defaults

---

The table below shows the defaults for some of the presets.

	Mini-60	Mini-O	Mini-D	Mini-P
Crank Time	20 sec	30 sec	20 sec	1 sec
Crank Delay	40 sec	60 sec	40 sec	60 sec
Crank Attempts	3	3	3	3
Relay 2 Function	Stop	Stop	Glow/Stop	Stop

All other settings use the following defaults:

Min Battery Charging Time	10 minutes
Max Battery Charging Time	720 minutes (12 hours)
Battery Cut-In Voltage	12.0, 24.0, or 48.0 volts*
Battery Cut-Out Voltage	13.8, 27.6, or 55.2 volts*
Battery Voltage Limit	14.5, 29.0, or 58.0 volts*
Battery Low Delay	300 seconds (5 minutes)
Battery High Delay	600 seconds (10 minutes)
AC Hz Tracking Enabled	No
Nominal AC Hz	60 Hz
Crank Cutoff Hz	35 Hz
Wifi Timeout	60 minutes

\*The default voltages for the battery settings will change based on the detected voltage of the battery or battery bank that is being monitored.

The GSCM-Wifi has an option available to reset all the default settings without accessing the wireless configuration page. This can be used in case the GSCM is not functioning correctly, and a power-off reset does not resolve the issue.

To perform the reset, hold down the “Wifi Toggle” button on the front face of the GSCM-Wifi for a full 10 seconds. The “Start” light will blink very quickly for 2 seconds and then the reset will occur. The GSCM-Wifi default settings are loaded from the “Mini-60” preset.

## Specifications

---

Size:	5.5"x3.25"x2"
Weight:	8oz
Temperature Range:	-40 to 85° C
Power:	9-15V DC
Quiescent Current:	~10mA when idle and Wifi off ~22-50mA with Wifi on ~45mA per Relay
Signal Input (Terminal 4):	12V DC
Battery Input (Terminal 3):	6-60V DC
DC Feedback (Terminal 5):	12V DC
AC Hz Input (Term 6 & 7):	24-220V AC 0-100Hz
Relay contacts:	24V DC max 10 Amp max

## Limited Warranty

---

Atkinson Electronics, Inc. gives this express warranty (along with extended warranty endorsements, where applicable) in lieu of all other warranties, express or implied, including (without limitation), warranties of merchantability and fitness for a particular purpose. This constitutes Atkinson Electronics, Inc.'s sole warranty and obligation with regard to our products as well as the Customer's sole remedy.

Atkinson Electronics, Inc. expressly disclaims all liability and responsibility for any special, indirect or consequential damages or any further loss of any kind whatsoever resulting from the use of our product. The Customer's sole and exclusive remedy and the limit of Atkinson Electronics, Inc.'s liability for any loss whatsoever, shall not exceed the purchase price paid by the Customer for the product to which a claim is made.

Countries or States that do not allow limitations of incidental or consequential damages or on how long an implied warranty lasts, the above limitations may not apply to you. This warranty gives you specific legal rights and you may also have other rights which vary from State to State or Country to Country.

All products manufactured by Atkinson Electronics, Inc. are warranted to be free from defects in material and workmanship in accordance with and subject to the following terms and conditions:

1. This warranty is limited to the original customer only. It cannot be transferred or assigned to third parties unless the intent to transfer to a third party is expressly indicated in a purchase order and/or warranty processing arrangements have been agreed upon in writing by Atkinson Electronics, Inc.
2. Atkinson Electronics, Inc. will correct any defects in material or workmanship which appear within two (2) years from the date of shipment by Atkinson Electronics, Inc. (or its authorized distributors) to the original Customer. Atkinson Electronics, Inc. will repair or replace, at our option, any defective products, provided that our inspection discloses that such defects developed under normal and proper use. This warranty does not extend to goods subjected to misuse, neglect, accident or improper installation, or to maintenance or repair of products which have been altered or repaired by anyone except Atkinson Electronics, Inc., unless otherwise stated in writing. Atkinson Electronics, Inc. will correct

any defects in material or workmanship of OEM products (designated as such in our catalog or web site) which appear within two (2) years from the product date code or from the factory invoice date, whichever is later.

3. An appropriate charge (25% of product list price) may be made for testing, repairs, replacement and shipping for a returned product which is not defective or found to be defective as the result of improper use, maintenance or neglect.
4. Atkinson Electronics, Inc. will not accept responsibility for any invoiced goods or services that are not covered by an Atkinson Electronics, Inc. written purchase order. Under no circumstances does Atkinson Electronics, Inc. agree to pay for labor or other related expenses associated with the troubleshooting and/or repair of our product without prior specific written authorization.
5. Information in our descriptive literature is based on product specifications that are current at the time of publication.

Product specifications, design and descriptive literature are subject to change as improvements are introduced. Although we announce changes as they occur, we cannot guarantee notification to every Customer. Atkinson Electronics, Inc. warrants delivered products to conform to the most current specifications, design and descriptive literature. This warranty policy may be expanded or limited, for particular categories of products or customers, by information sheets published as deemed appropriate by Atkinson Electronics, Inc.